

SECTION 5

ELECTRICAL WIRING DIAGRAMS

5-2 ELECTRICAL WIRING DIAGRAMS

1. STARTING & CHARGING SYSTEM

1) BATTERY, IGNITION SWITCH, STARTER MOTOR, ALTERNATOR & SWITCH (CLUTCH(M/T), NSBU(A/T))

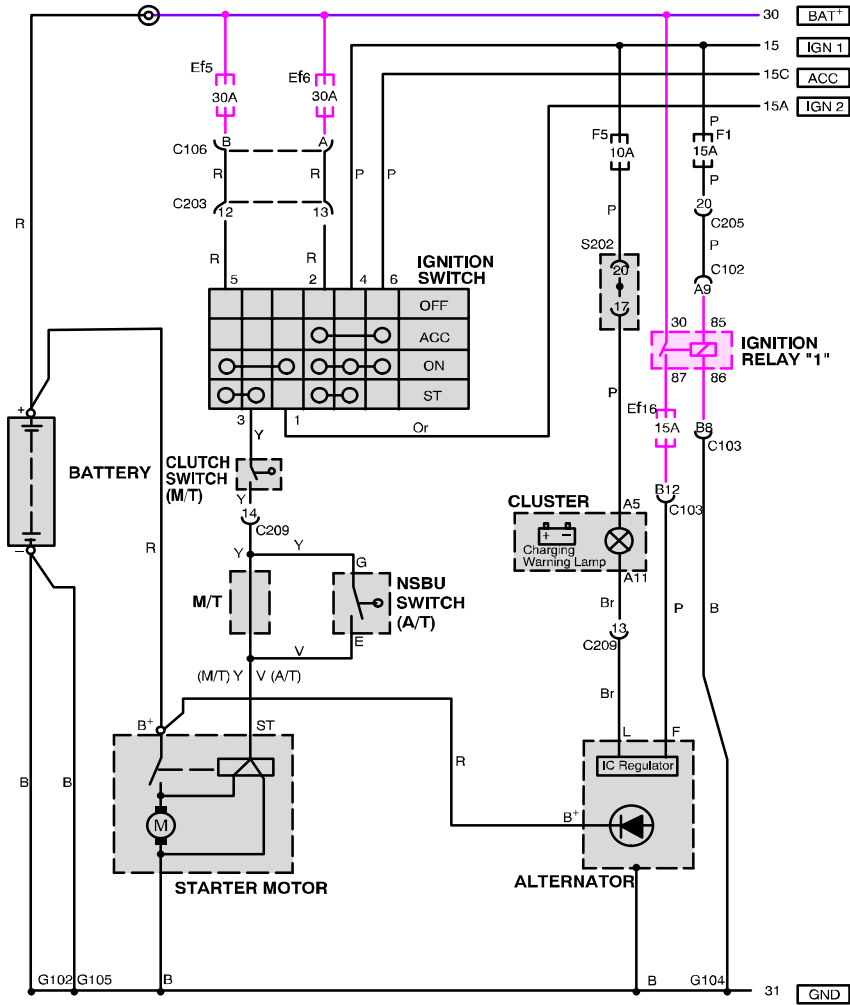

a. CONNECTOR INFORMATION

CONNECTOR(NO) (PIN NO. COLOR)	CONNECTING, WIRING HARNESS	CONNECTOR POSITION
C102(68 Pin, Brown)	Engine Room Fuse Box – Body	Engine Room Fuse Box
C103(68Pin, Black)	Engine Room Fuse Box – Engine Control	Engine Room Fuse Box
C106(2 Pin, Colorless)	Engine Room Fuse Box – Body	Engine Room Fuse Box
C203(15 Pin, White)	I.P – Body	Left Driver Leg Room Connector Holder
C205(20 Pin, Colorless)	I.P – Body	Right Driver Leg Room Connector Holder
C209(20 Pin, Colorless)	I/P – Engine Control	Upper Co–driver Right Kick Panel
S202(Blue)	IP	Upper Driver Leg Room
G102	Battery & ABS	Between Battery and Fuse Box
G104	Engine Control	Cylinder Head Next to #4 Intake Manifold
G105	Battery	Next to Starter Motor

b. CONNECTOR IDENTIFICATION SYMBOL & PIN NUMBER POSITION

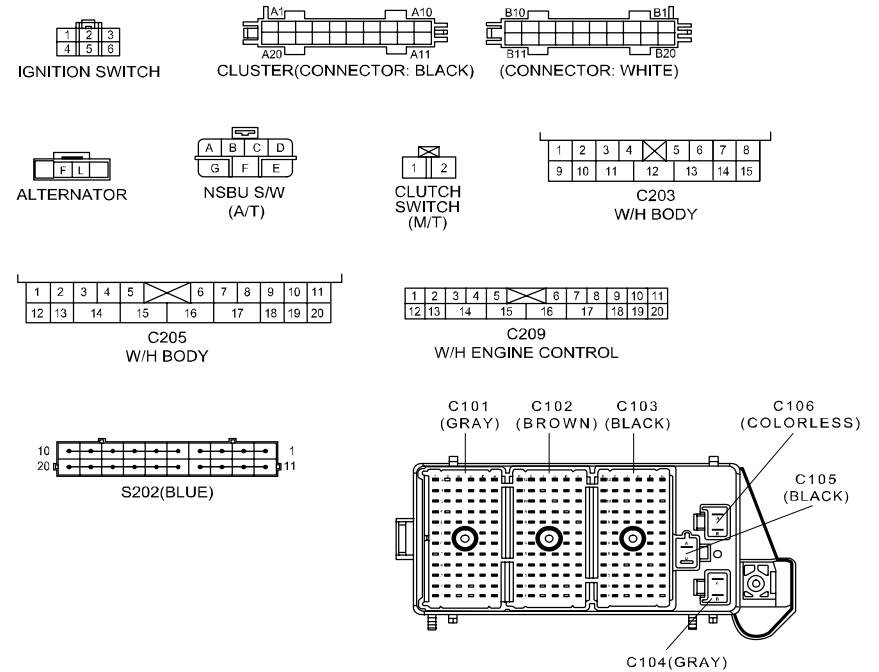

c. POSITION OF CONNECTORS AND GROUNDS

- ENGINE ROOM FUSE BLOCK

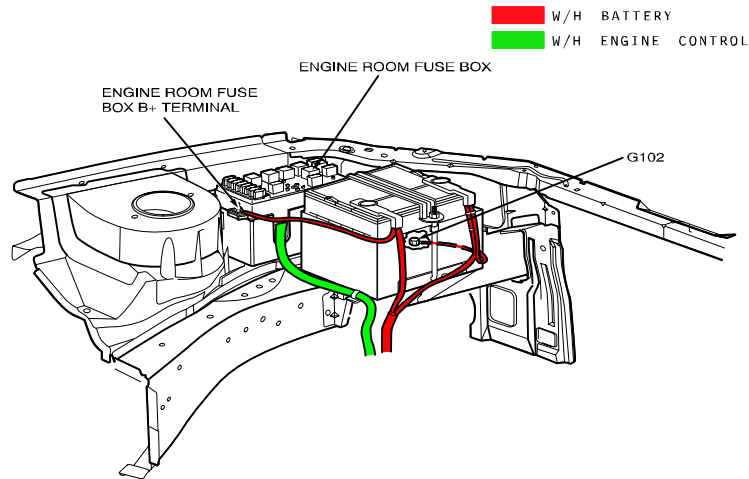

- LEFT "A" PILLAR INSIDE

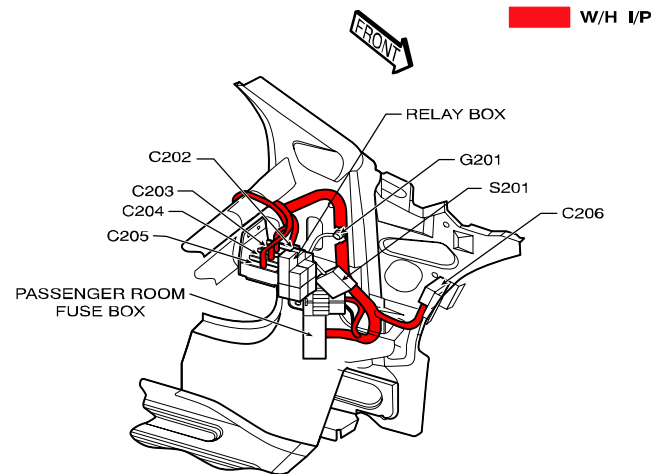

- 2.0 DOHC ENGINE

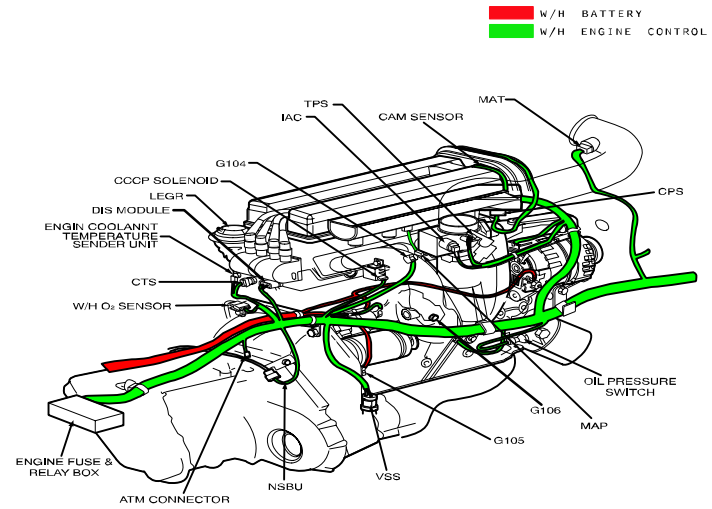

d. SPLICE PACK

S202 (BLUE)

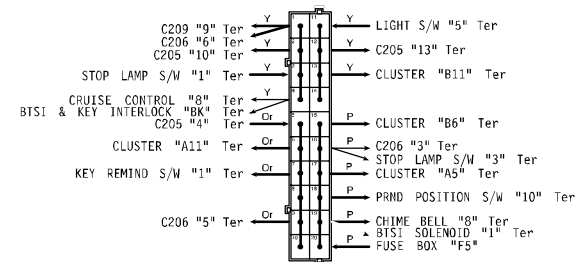

SECTION 3

WIRING DIAGRAM FOR POWER SUPPLIES

1. IGNITION SWITCH CIRCUIT

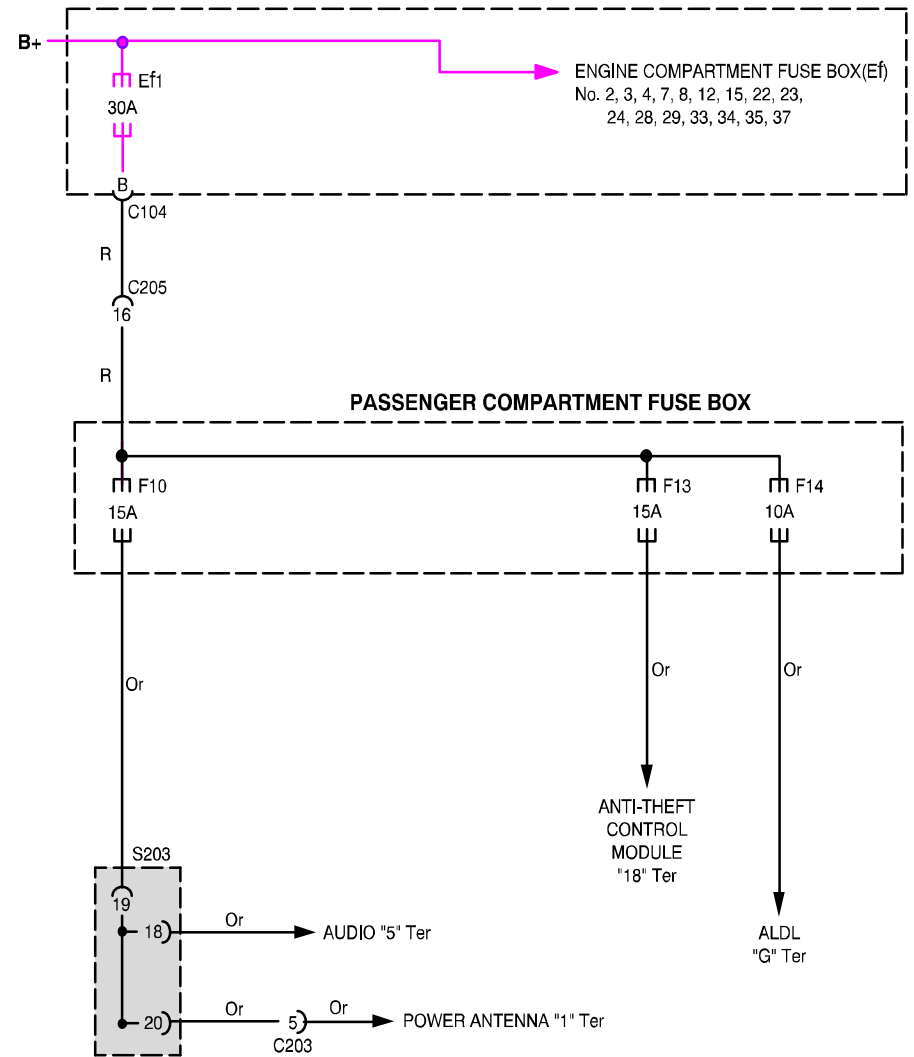
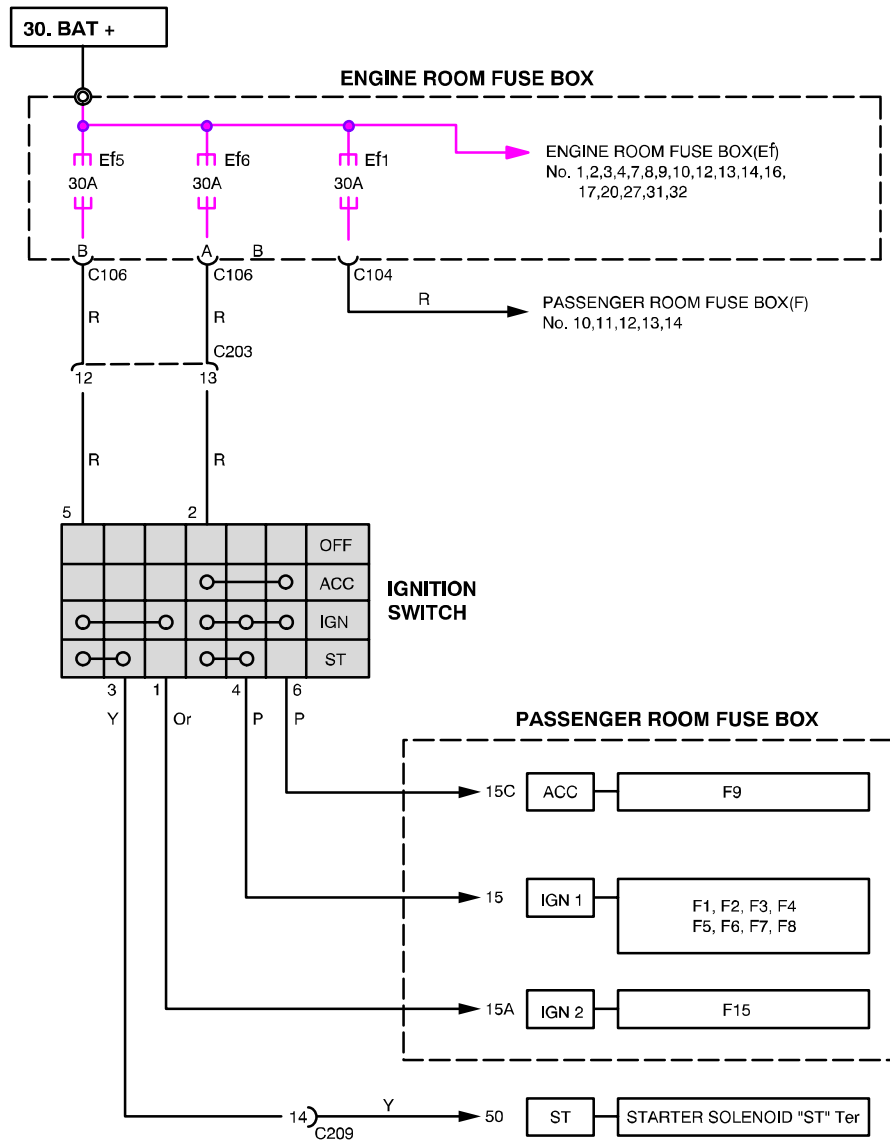

2. 30 Ter BAT+ POWER SUPPLY CIRCUIT(PASSENGER ROOM FUSE BOX)

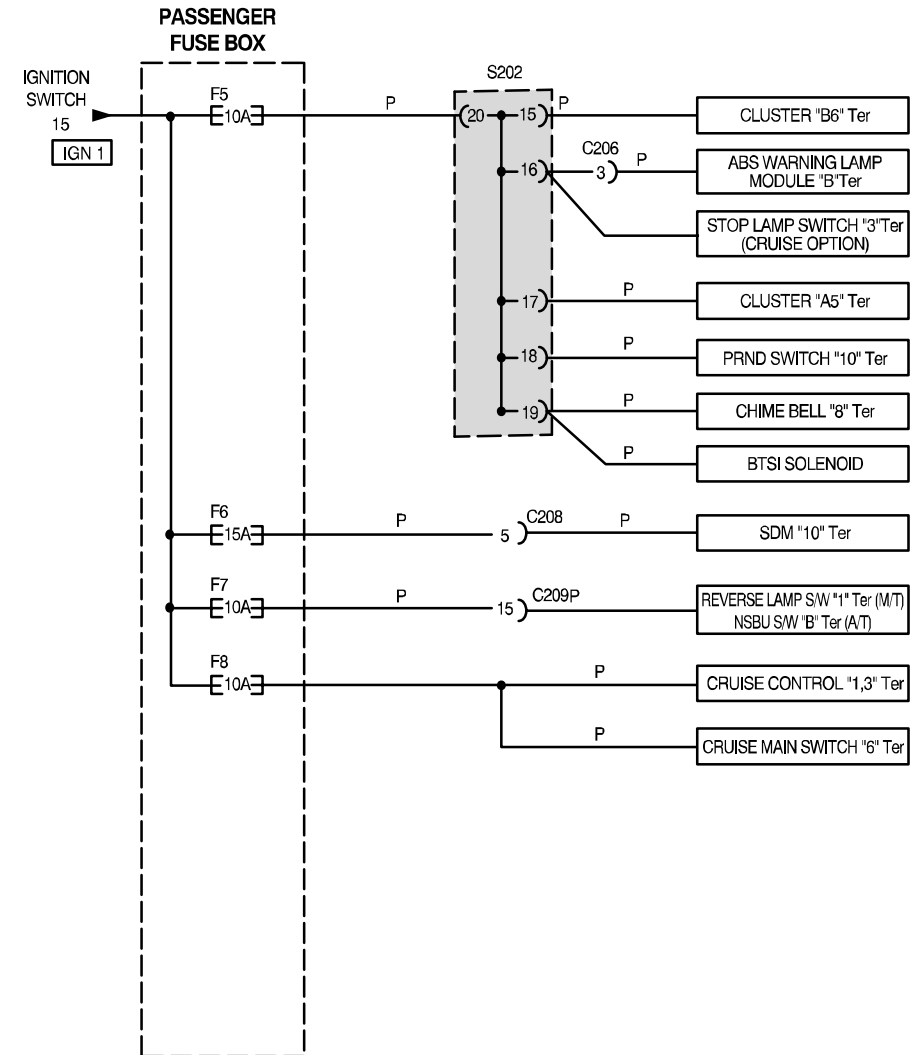
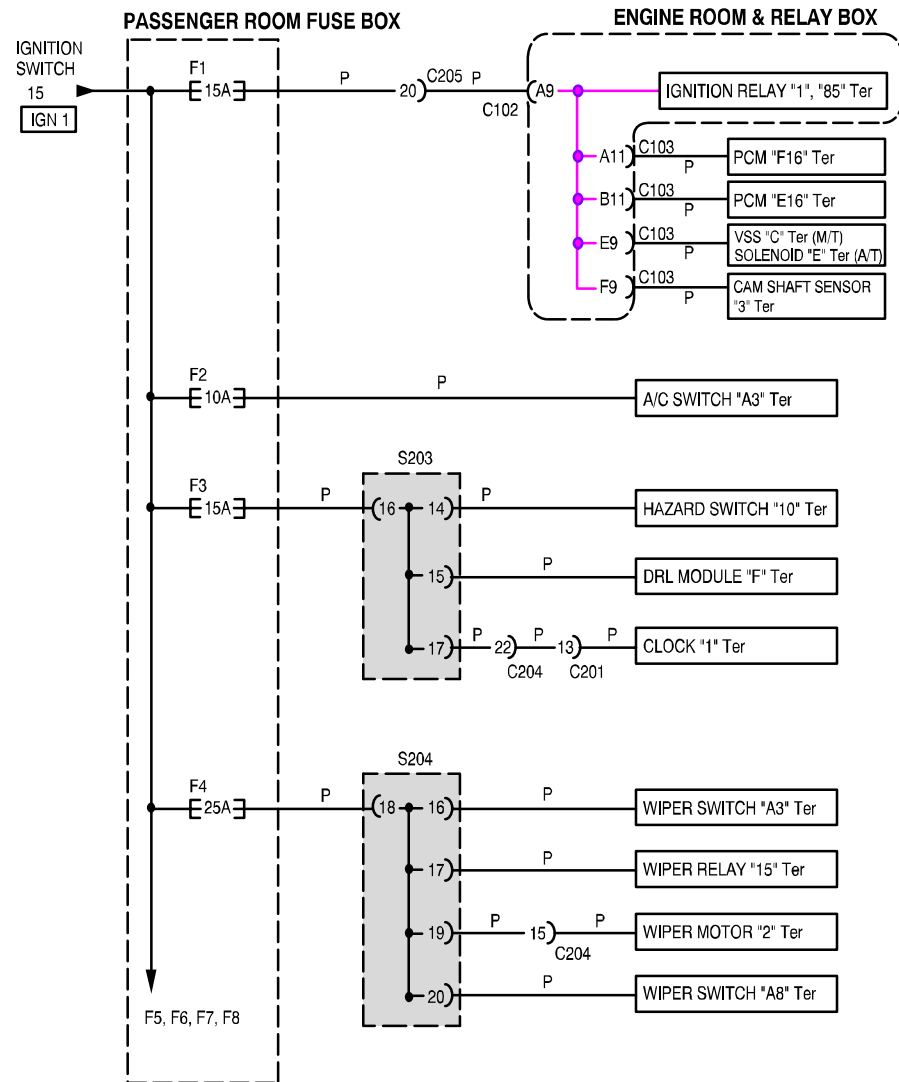

3-4 WIRING DIAGRAM FOR POWER SUPPLIES

3. 15A IGN 2, 15C ACC POWER SUPPLY CIRCUIT(PASSENGER ROOM FUSE BOX)

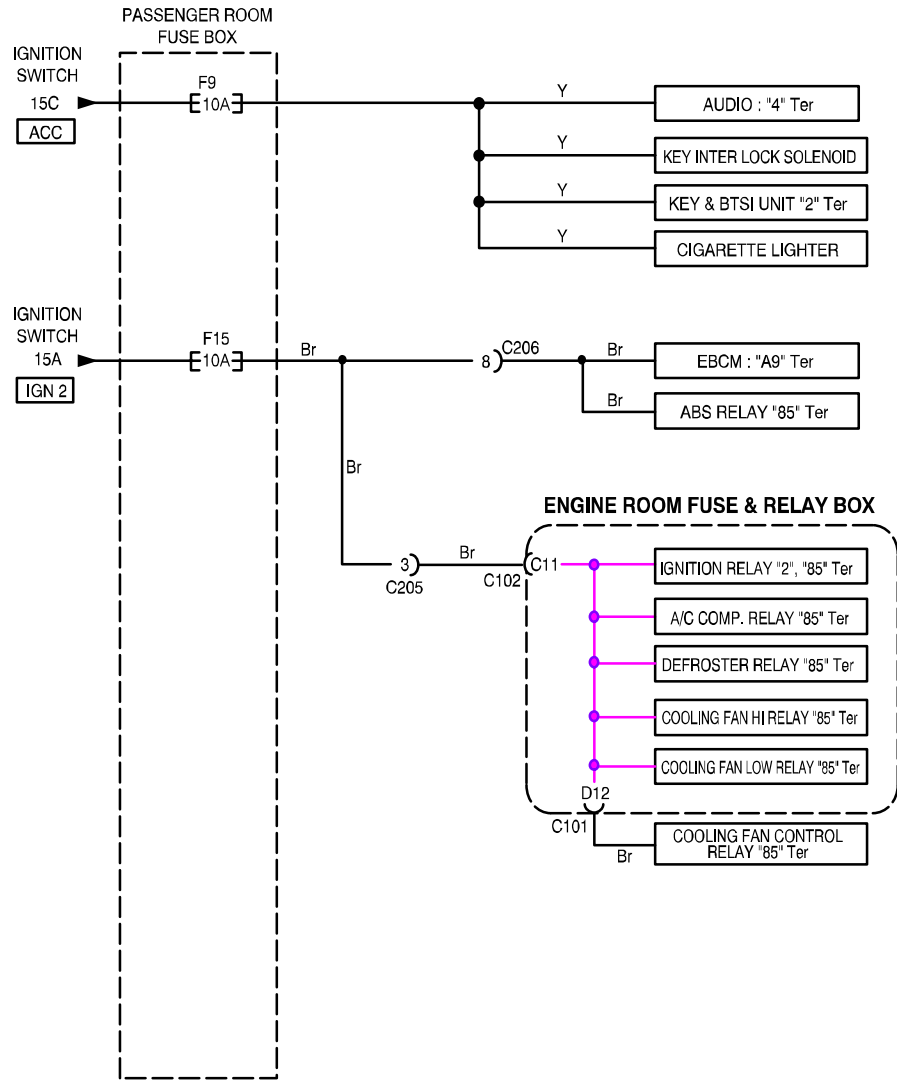

4. ENGINE ROOM FUSE & RELAY CIRCUIT

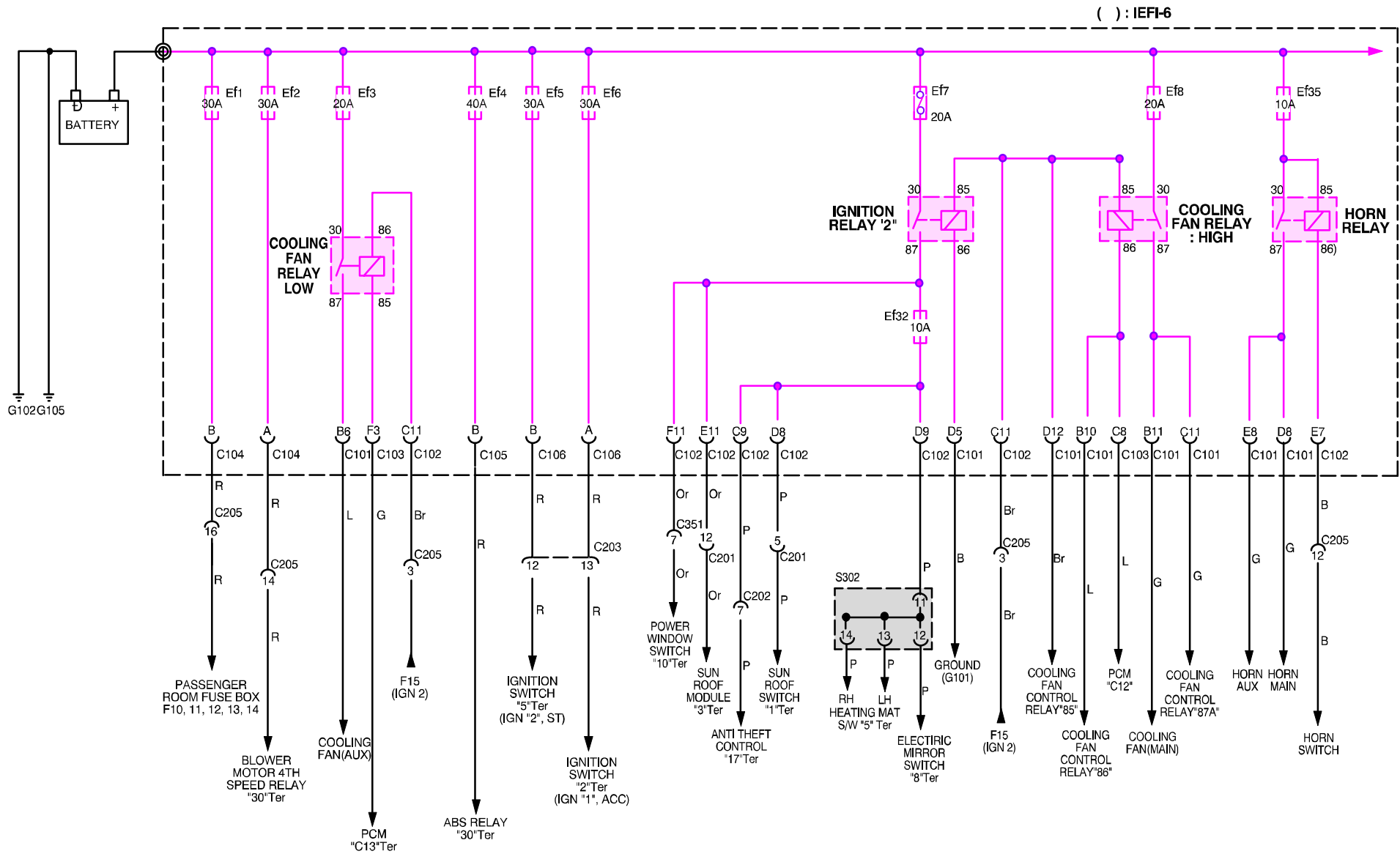

3-6 WIRING DIAGRAM FOR POWER SUPPLIES

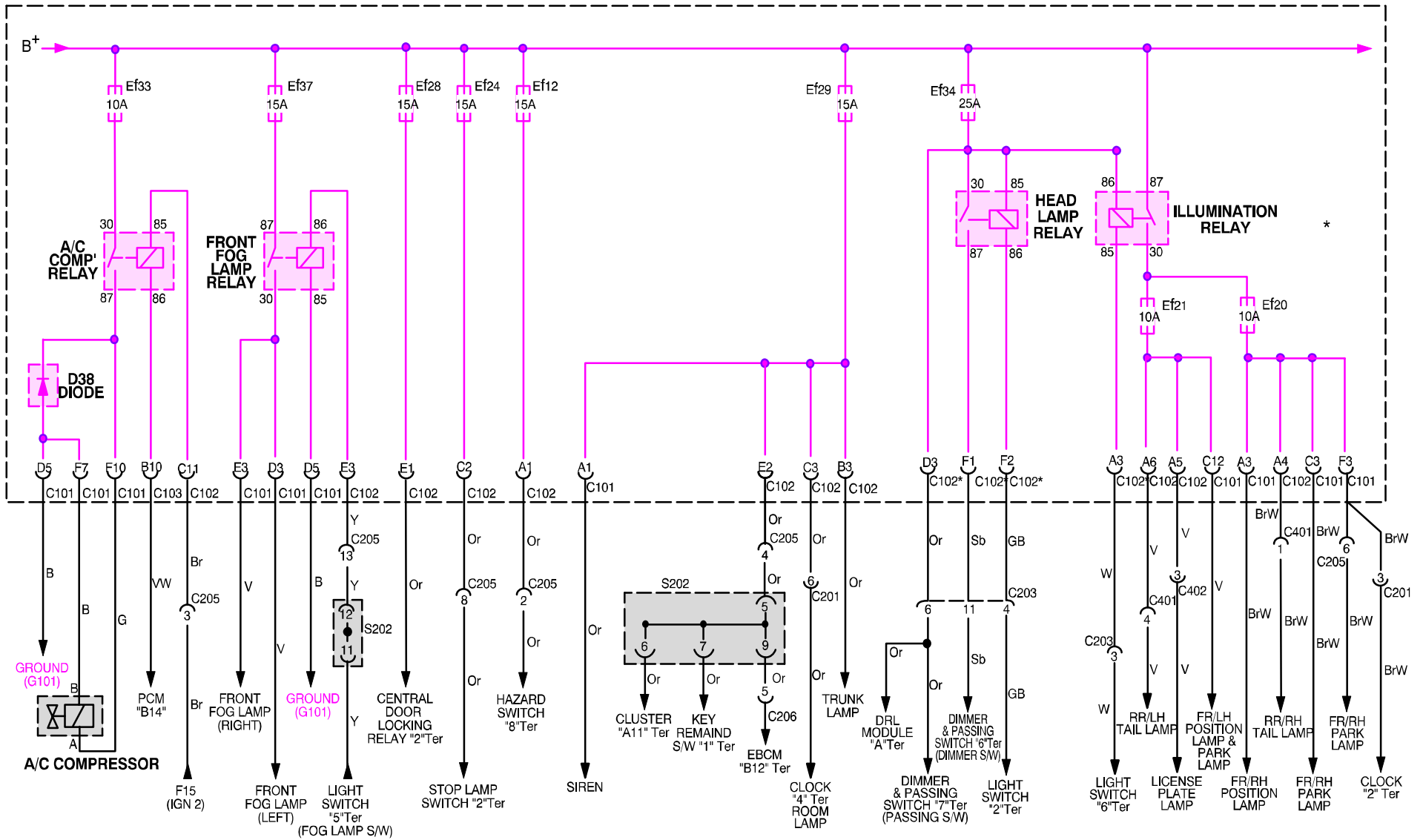

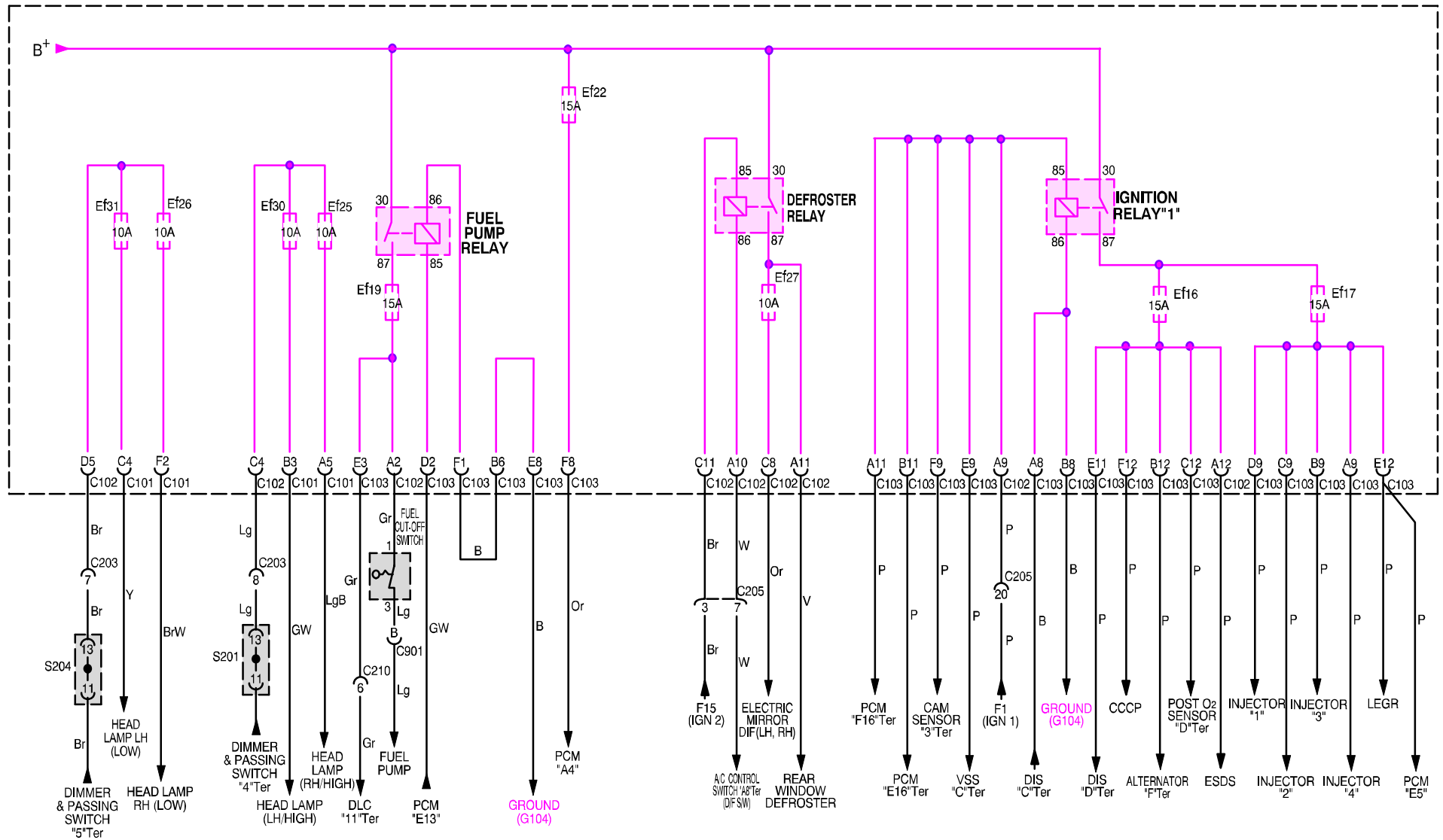

SECTION 4

USAGE AND CAPACITY OF FUSES

1. ENGINE COMPARTMENT RELAY AND FUSE BOX

1) POSITION OF RELAY AND FUSE

• Front View

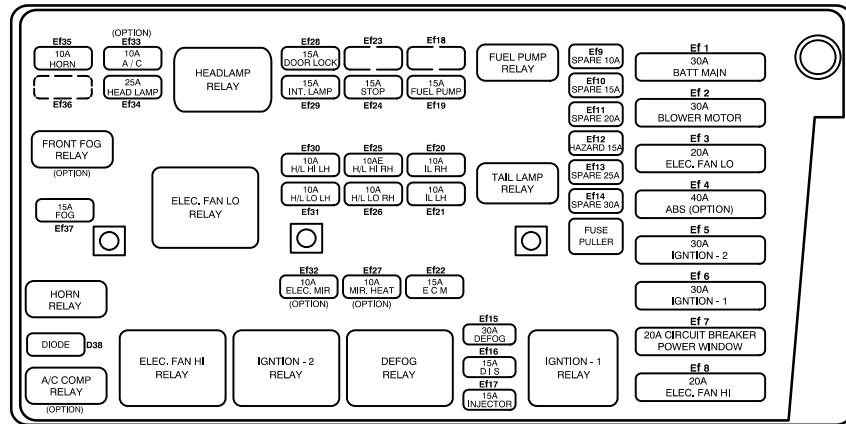

• Rear View

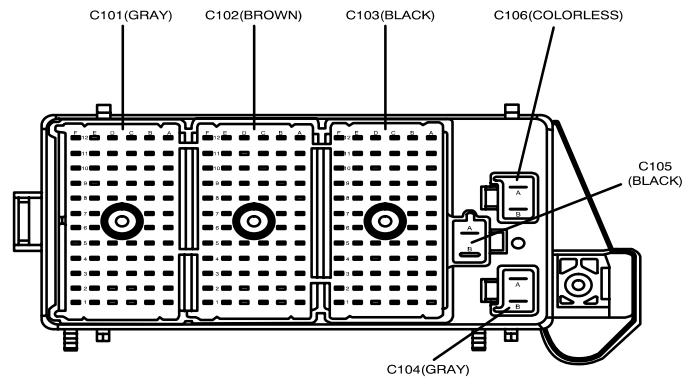

2) USAGE OF FUSES IN ENGINE COMPARTMENT FUSE BOX

Power Supply	Classification	Fuse No	Capacity	Usage
30 BAT(+)	SB(Slow-Blown Fuse)	Ef 1	30A	Battery Main (F10, F11, F12, F13, F14)
		Ef 2	30A	Blower Motor
		Ef 3	20A	Cooling Fan Low Speed
		Ef 4	40A	ABS (Option)
		Ef 5	30A	Ignition-2(Key)
		Ef 6	30A	Ignition-1(Key)
	Circuit Brake	Ef 7	20A	Ignition Relay "2"(Power Window)
	SB Fuse	Ef 8	20A	Cooling Fan High Speed
Spare	Blade Type Fuse	Ef 9	10A	Not Used
30 BAT(+)		Ef 10	15A	Not Used
Spare		Ef 11	20A	Not Used
30 BAT(+)		Ef 12	15A	Hazard
Spare		Ef 13	25A	Not Used
30 BAT(+)		Ef 14	30A	Not Used
IGN 1 (15)		Ef 15	30A	Defroster
		Ef 16	15A	DIS
		Ef 17	15A	Injector
Illumination (58)		Ef 18		Not Used
		Ef 19	15A	Fuel pump
		Ef 20	10A	Illumination RH
30 BAT(+)		Ef 21	10A	Illumination LH
		Ef 22	15A	ECM
		Ef 23	-	Not Used
Light (58)		Ef 24	15A	Brake Lamp (Stop Lamp)
		Ef 25	10A	Head Lamp Hi Beam RH
IGN 2(15A)		Ef 26	10A	Head Lamp Low Beam RH
		Ef 27	10A	Electric Mirror Heat
30 BAT(+)		Ef 28	15A	Central Door Locking
		Ef 29	15A	ABS, Cluster, Remind S/W, Clock
Light (58)		Ef 30	10A	Heat Lamp Hi Beam LH
		Ef 31	10A	Heat Lamp Low Beam LH
IGN 2(15A)		Ef 32	10A	Electric Mirror, Heating Mat
		Ef 33	10A	Air Conditioner
30 BAT(+)		Ef 34	25A	Head Lamp
		Ef 35	10A	Horn
		Ef 36	-	Not Used
		Ef 37	15A	Fog Lamp
		Diode	D 38	-

4-3 USAGE AND CAPACITY OF FUSES

2. PASSENGER ROOM FUSE BOX

1) POSITION OF FUSE AND RELAY

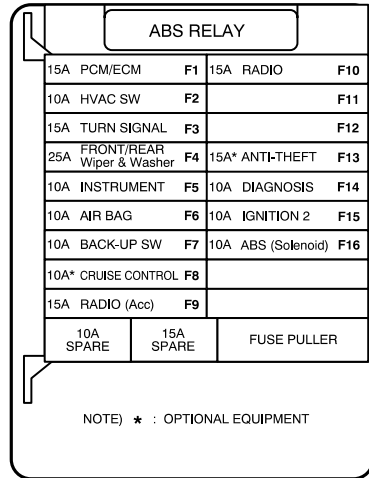

2) USAGE OF FUSES IN PASSENGER ROOM FUSE BOX

Power Supply	Classification	Fuse No	Capacity	Usage	
15 IGN "1" ON	Blade Type	F1	15A	PCM, Ignition Relay "1"	
		F2	10A	Airconditioning System	
		F3	15A	Hazard, Clock, DRL	
		F4	25A	Wiper System	
		F5	10A	Cluster, ABS, Chime Bell, PRND Switch, Brake	
		F6	10A	SDM(Air Bag)	
		F7	10A	Reverse(Back Up) Lamp	
		F8	10A	Cruise Control	
		15C ACC	F9	15A	Audio, Cigarette Lighter, Key & BTSI
		BAT+ 30A	F10	15A	Auto Antenna, Audio
F11			-	Not Used	
F12			-	Not Used	
F13			15A	Anti Theft	
System Voltage		F14	10A	DLC "16" Terminal	
		F15	10A	ABS, A/C, Defroster, Ignition Relay "2"	
		F16	10A	ABS	

* 30 : BAT(+) Power Supply Through Ef1.

3. POSITION OF CONTROL UNIT, RELAY AND PART NUMBER

1) ENGINE ROOM FUSE BOX

Part Name	Part No	Remarks
Fuel Pump Relay	96190187	4 Pin
Fog Lamp Relay	96190187	
Horn Relay	96190187	
Illumination Relay	96190187	
Head Lamp Relay	96190187	
A/C Compressor Relay	96190187	
Rear Window Defroster Relay	96190189	4 Pin
Radiator Cooling Fan High Speed Relay	96190189	
Radiator Cooling Fan Low Speed Relay	96190189	
IGN 1 Relay	96190189	
IGN 2 Relay	96190189	

2) PASSENGER ROOM FUSE BOX

Part Name	Part No	Remarks
ABS Relay	12088595	

3) BEHIND DRIVER LEG ROOM CONNECTOR HOLDER

Part Name	Part No	Remarks
Blinker Unit(Turn Signal Relay)	96312545	
Wiper Relay	96250544	
Blower Motor 4th Speed Relay	96190189	
BTSS & Key Interlock Unit	96312299	

4) UPPER DRIVER LEG ROOM

Part Name	Part No	Remarks
Chime Bell	96219056	

5) BEHIND LEFT HEAD LAMP

Part Name	Part No	Remarks
Radiator Cooling Fan Control Relay	96312958	

6) BEHIND DRIVER SIDE LEFT KICK PANEL

Part Name	Part No	Remarks
E B C M	96313430	
Central Door Locking Relay	96312298	

7) FLOOR PANEL BEHIND I/P CENTER PART

Part Name	Part No	Remarks
Anti-Theft Control Unit	96190181	
DRL (Day Time Running Light) Module	96240514	

8) FLOOR PANEL BELOW FRONT CONSOLE

Part Name	Part No	Remarks
S D M	96312354	

SECTION : 9B

LIGHTING SYSTEMS

CAUTION : *Disconnect the negative battery cable before removing or installing any electrical unit or when a tool or equipment could easily come in contact with exposed electrical terminals. Disconnecting this cable will help prevent personal injury and damage to the vehicle. The ignition must also be in LOCK unless otherwise noted.*

TABLE OF CONTENTS

SPECIFICATIONS	9B-2	REAR COMBINATION LAMPS	9B-39
BULB USAGE CHART	9B-2	CENTER HIGH-MOUNTED STOPLAMP (NOTCHBACK)	9B-40
FASTENER TIGHTENING SPECIFICATIONS .	9B-2	CENTER HIGH-MOUNTED STOPLAMP (HATCHBACK)	9B-40
SCHEMATIC AND ROUTING DIAGRAMS	9B-3	CENTER HIGH-MOUNTED STOPLAMP (WAGON) 9 B-41	
HEADLAMPS-ON REMINDER CHIME CIRCUIT	9B-3	LICENSE PLATE LAMPS	9B-42
PARKING, TAIL, POSITION AND LICENSE LAMPS CIRCUIT	9B-4	DOOR JAMB SWITCH	9B-42
TURN AND HAZARD LAMPS CIRCUIT	9B-5	INTERIOR COURTESY LAMP	9B-43
BRAKE AND BACKUP LAMPS CIRCUIT	9B-6	MAP LAMP	9B-44
INTERIOR COURTESY LAMP AND LUGGAGE COMPARTMENT LAMP CIRCUIT	9B-7	GLOVE BOX LAMP	9B-44
HEADLAMPS CIRCUIT	9B-8	ASHTRAY LAMP	9B-45
DAYTIME RUNNING LAMPS CIRCUIT	9B-9	LUGGAGE COMPARTMENT LAMP	9B-46
FOG LAMPS CIRCUIT	9B-10	CARGO AREA LAMP (WAGON)	9B-46
DIAGNOSIS	9B-11	DAYTIME RUNNING LAMP MODULE	9B-47
HEADLAMPS-ON REMINDER CHIME	9B-11	GENERAL DESCRIPTION AND SYSTEM	
HEADLAMPS	9B-12	OPERATION	9B-48
FOG LAMPS	9B-18	HEADLAMPS-ON REMINDER	9B-48
REAR COMBINATION LAMPS	9B-19	HEADLAMPS	9B-48
INTERIOR COURTESY AND LUGGAGE COMPARTMENT LAMPS	9B-28	DAYTIME RUNNING LAMPS	9B-48
MAINTENANCE AND REPAIR	9B-31	PARKING AND TURN SIGNAL LAMPS	9B-48
ON-VEHICLE SERVICE	9B-31	SIDE MARKER LAMPS	9B-48
HEADLAMPS/FRONT TURN SIGNAL LAMPS	9B-31	FOG LAMPS	9B-48
HEADLAMP AIMING	9B-34	REAR COMBINATION LAMPS	9B-48
PARKING LAMPS	9B-35	LICENSE PLATE LAMP	9B-49
SIDE MARKER LAMPS	9B-36	INTERIOR COURTESY LAMP	9B-49
FOG LAMPS	9B-37	GLOVE BOX LAMP	9B-49
		ASHTRAY LAMP	9B-49
		LUGGAGE COMPARTMENT LAMP	9B-49

SPECIFICATIONS

BULB USAGE CHART

Bulb	Replacement Bulb Number
Backup Lamp	27W
Center High–Mounted Stoplamp	21W
Fog Lamp	55W
Glove Box Lamp	10W
Headlamp	Double 60/55W
Interior Courtesy Lamp	10W
License Plate Lamp	5W
Luggage Compartment Lamp	10W
Park and Front Turn Signal Lamp	Double 27/8W
Rear Turn Signal Lamp	Single 27/8W
Side Marker Lamp	8W
Taillamp and Stoplamp	Double 27/8W

FASTENER TIGHTENING SPECIFICATIONS

Application	N•m	Lb–Ft	Lb–In
CHMSL Mounting Nuts	4	–	35
CHMSL Mounting Screws	4	–	35
Daytime Running Lamp Module Screws	4	–	35
Door Jamb Switch Screw	4	–	35
Fog Lamp Nuts	4	–	35
Headlamp Assembly Bolts	4	–	35
Headlamp Assembly Nut	4	–	35
License Plate Lamp Screws	4	–	35
Map Lamp Screws	1	–	9
Rear Combination Lamp Assembly Screws	4	–	35

SECTION : 9U

CRUISE CONTROL SYSTEM

CAUTION : *Disconnect the negative battery cable before removing or installing any electrical unit or when a tool or equipment could easily come in contact with exposed electrical terminals. Disconnecting this cable will help prevent personal injury and damage to the vehicle. The ignition must also be in LOCK unless otherwise noted.*

TABLE OF CONTENTS

SPECIFICATIONS	9U-1	MAINTENANCE AND REPAIR	9U-11
FASTENER TIGHTENING SPECIFICATIONS .	9U-1	ON-VEHICLE SERVICE	9U-11
SCHEMATIC AND ROUTING DIAGRAMS	9U-2	CRUISE CONTROL ACTUATOR	9U-11
CRUISE CONTROL SYSTEM (AUTOMATIC TRANSAXLE) (1 OF 2)	9U-2	ACTUATOR CONTROL CABLE	9U-15
CRUISE CONTROL SYSTEM (AUTOMATIC TRANSAXLE) (2 OF 2)	9U-3	MAIN SWITCH	9U-17
CRUISE CONTROL SYSTEM (MANUAL TRANSAXLE) (1 OF 2)	9U-4	GENERAL DESCRIPTION AND SYSTEM	
CRUISE CONTROL SYSTEM (MANUAL TRANSAXLE) (2 OF 2)	9U-5	OPERATION	9U-19
DIAGNOSIS	9U-6	CRUISE CONTROL SYSTEM OPERATION .	9U-19
CRUISE CONTROL DIAGNOSIS	9U-6	CRUISE CONTROL ACTUATOR	9U-19
		MAIN SWITCH	9U-19
		LEVER SWITCH	9U-19

SPECIFICATIONS

FASTENER TIGHTENING SPECIFICATIONS

Application	N•m	Lb-Ft	Lb-In
Actuator Bolts	4	–	35
Actuator Bracket Nuts	18	13	–

CRUISE CONTROL SYSTEM (MANUAL TRANSAXLE) (1 OF 2)

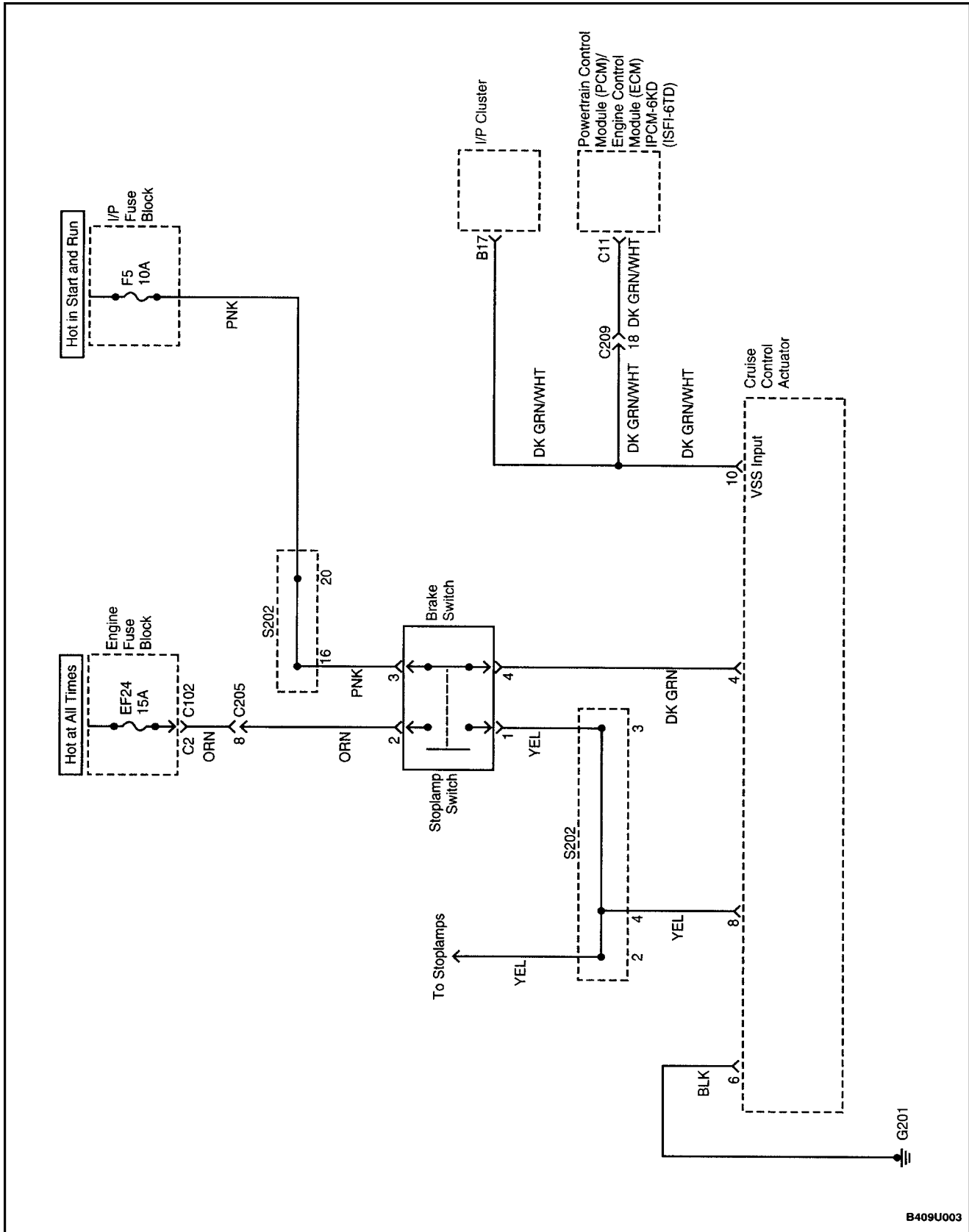

SECTION : 9F

AUDIO SYSTEMS

CAUTION : *Disconnect the negative battery cable before removing or installing any electrical unit or when a tool or equipment could easily come in contact with exposed electrical terminals. Disconnecting this cable will help prevent personal injury and damage to the vehicle. The ignition must also be in LOCK unless otherwise noted.*

TABLE OF CONTENTS

<p>SPECIFICATIONS 9F-1</p> <p style="padding-left: 20px;">FASTENER TIGHTENING SPECIFICATIONS . 9F-1</p> <p>SCHEMATIC AND ROUTING DIAGRAMS 9F-2</p> <p style="padding-left: 20px;">AUDIO SYSTEM CIRCUIT 9F-2</p> <p>DIAGNOSIS 9F-3</p> <p style="padding-left: 20px;">STEREO CASSETTE AM/FM RADIO 9F-3</p> <p style="padding-left: 20px;">SPEAKERS 9F-5</p> <p style="padding-left: 20px;">ANTENNA 9F-6</p> <p>MAINTENANCE AND REPAIR 9F-8</p> <p>ON-VEHICLE SERVICE 9F-8</p> <p style="padding-left: 20px;">STEREO CASSETTE AM/FM RADIO 9F-8</p> <p style="padding-left: 20px;">FRONT DOOR SPEAKERS 9F-9</p> <p style="padding-left: 20px;">TWEETER SPEAKERS 9F-10</p> <p style="padding-left: 20px;">REAR SPEAKERS (NOTCHBACK) 9F-10</p> <p style="padding-left: 20px;">REAR SPEAKERS (HATCHBACK) 9F-11</p>	<p style="padding-left: 20px;">MAST ANTENNA 9F-12</p> <p style="padding-left: 20px;">ROOF ANTENNA 9F-13</p> <p style="padding-left: 20px;">POWER ANTENNA MAST(NOTCHBACK) ... 9F-13</p> <p style="padding-left: 20px;">POWER ANTENNA MOTOR (NOTCHBACK) 9F-14</p> <p style="padding-left: 20px;">COMPACT DISC CHANGER 9F-15</p> <p>GENERAL DESCRIPTION AND SYSTEM OPERATION 9F-17</p> <p style="padding-left: 20px;">AUDIO SYSTEMS 9F-17</p> <p style="padding-left: 20px;">AUDIO SECURITY SYSTEM 9F-17</p> <p style="padding-left: 20px;">FRONT AND REAR SPEAKERS 9F-17</p> <p style="padding-left: 20px;">TWEETER SPEAKERS 9F-17</p> <p style="padding-left: 20px;">MAST ANTENNA 9F-17</p> <p style="padding-left: 20px;">POWER ANTENNA 9F-17</p> <p style="padding-left: 20px;">ROOF ANTENNA 9F-17</p> <p style="padding-left: 20px;">TAPE PLAYER AND CASSETTE CARE 9F-17</p> <p style="padding-left: 20px;">COMPACT DISC CARE 9F-17</p>
---	--

SPECIFICATIONS

FASTENER TIGHTENING SPECIFICATIONS

Application	N•m	Lb-Ft	Lb-In
Antenna Cap Nut	7	–	62
Antenna Motor Nuts	7	–	62
Audio System Bolts	4	–	35
CD Changer Nuts	7	–	62
Mast Antenna Base Nut	4	–	35
Front Door Speaker Screws	4	–	35
Rear Speaker Screws	4	–	35
Roof Antenna Nut	10	–	89

SCHEMATIC AND ROUTING DIAGRAMS

AUDIO SYSTEM CIRCUIT

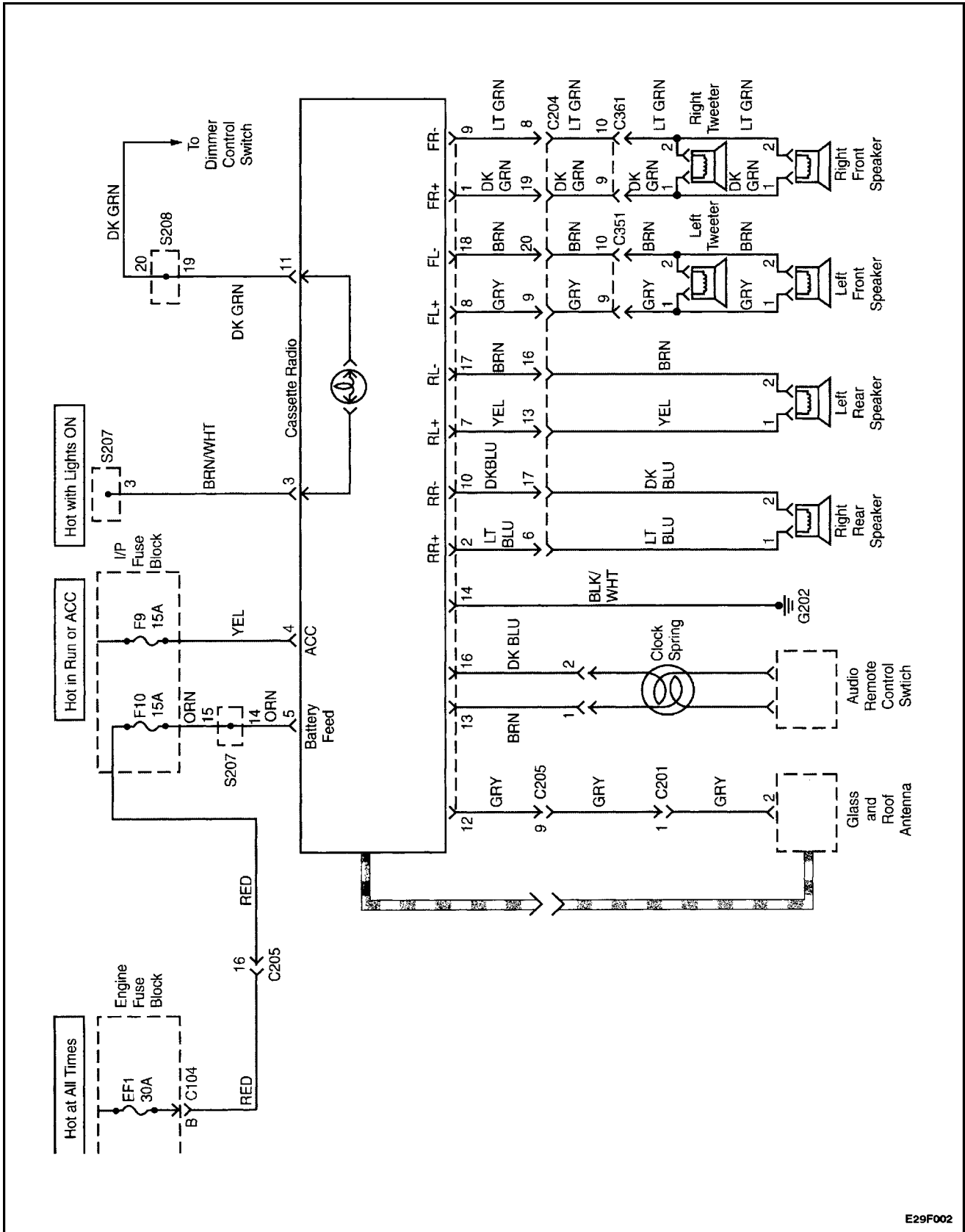

DIAGNOSIS

STEREO CASSETTE AM/FM RADIO

Cassette AM/FM Radio Inoperative

Step	Action	Value(s)	Yes	No
1	Check fuses EF1, F9, and F10. Are fuses EF1, F9, and F10 blown?		Go to <i>Step 2</i>	Go to <i>Step 3</i>
2	1. Check for a short circuit and repair if necessary. 2. Replace the blown fuses. Is the repair complete?		System OK	
3	1. Use a voltmeter to test for battery voltage at fuses EF1 and F10. 2. Turn the ignition ON and test for battery voltage at fuse F9. Does the battery voltage match the specified value at fuses EF1, F9, and F10?	11–14 v	Go to <i>Step 5</i>	Go to <i>Step 4</i>
4	Repair the power supply circuit to the fuses. Is the repair complete?		System OK	
5	1. Disconnect the radio electrical connector. 2. Turn the ignition ON. 3. Use a voltmeter to test for battery voltage at the radio connector terminals 4 and 5. Does the battery voltage match the specified value at both terminals?	11–14 v	Go to <i>Step 7</i>	Go to <i>Step 6</i>
6	Repair the open circuit between the radio connector and the fuse. Is the repair complete?		System OK	
7	Use an ohmmeter to test the ground circuit at the radio connector terminal 14. Does the resistance match the specified value?	0–0.5 Ω	Go to <i>Step 9</i>	Go to <i>Step 8</i>
8	Repair the open ground circuit between the radio connector and ground G105. Is the repair complete?		System OK	
9	Replace the radio. Is the repair complete?		System OK	

Cassette Player Inoperative, AM/FM Functions OK

Step	Action	Value(s)	Yes	No
1	Verify the customer complaint. Does the cassette player destroy tapes?		Go to <i>Step 5</i>	Go to <i>Step 2</i>
2	Using a good-quality tape, determine whether the cassette player performs poorly or is inoperative. Does the cassette player perform poorly?		Go to <i>Step 5</i>	Go to <i>Step 3</i>
3	Check the cassette player for obstructions behind the tape door. Is an obstruction found?		Go to <i>Step 4</i>	Go to <i>Step 8</i>

9F – 4 AUDIO SYSTEMS

Step	Action	Value(s)	Yes	No
4	Check to see if the obstruction can be removed using gentle force. Is the obstruction removed?		Go to <i>Step 5</i>	Go to <i>Step 6</i>
5	Clean the cassette player head, the capstan, and the drive system. Does the tape play properly?		Go to <i>Step 7</i>	Go to <i>Step 6</i>
6	Replace the radio. Is the repair complete?		System OK	
7	Check the cassette player for normal operation. Is the repair complete?		System OK	
8	Advise the owner of a defective or worn tape. Is the repair complete?		System OK	

AM Does Not Work, FM and Cassette OK

Step	Action	Value(s)	Yes	No
1	Replace the radio. Is the repair complete?			

FM Radio Does Not Work, AM and Cassette OK

Step	Action	Value(s)	Yes	No
1	1. Unplug the antenna cable from the antenna. 2. Connect the test antenna to the antenna cable. 3. Check the FM radio reception. Is the FM radio operating properly?		Go to <i>Step 2</i>	Go to <i>Step 3</i>
2	Replace the antenna. Is the repair complete?		System OK	
3	1. Remove the radio from the instrument panel. 2. Unplug the antenna cable from the radio. 3. Plug the test antenna into the radio. 4. Check the FM radio reception. Is the FM radio operating properly?		Go to <i>Step 4</i>	Go to <i>Step 5</i>
4	Replace the antenna cable between the radio and the antenna. Is the repair complete?		System OK	
5	Replace the radio. Is the repair complete?		System OK	

SPEAKERS

Front Speakers Distorted or Inoperative, Rest of Audio System OK

Step	Action	Value(s)	Yes	No
1	1. Turn the ignition and the radio ON. 2. Check for distorted or inoperative front speakers using the fader and the balance controls with all of the sources (AM, FM, tape, CD). Are the front speakers distorted?		Go to <i>Step 2</i>	Go to <i>Step 4</i>
2	Check the speaker and the door area for damage, rattles, or vibration. Is there anything loose or in the way of the speaker causing the distortion?		Go to <i>Step 3</i>	Go to <i>Step 4</i>
3	Make the necessary repairs to secure the component causing the distortion. Is the repair complete?		System OK	
4	1. Remove the front speakers and disconnect the speaker connector. 2. Using an ohmmeter, test the speaker wires for a short to ground. Does the ohmmeter show the specified value?	∞	Go to <i>Step 6</i>	Go to <i>Step 5</i>
5	Repair the short circuit between the front speaker connector and the radio connector. Is the repair complete?		System OK	
6	Substitute a known good speaker for the speaker causing the distortion. Is the distortion eliminated?		Go to <i>Step 7</i>	Go to <i>Step 8</i>
7	Replace the speaker. Is the repair complete?		System OK	
8	Replace the radio. Is the repair complete?		System OK	

Rear Speakers Distorted or Inoperative, Rest of Audio System OK

Step	Action	Value(s)	Yes	No
1	1. Turn the ignition and the radio ON. 2. Check for distorted or inoperative rear speakers using the fader and the balance controls with all the of the sources (AM, FM, tape, CD). Are the rear speakers distorted?		Go to <i>Step 2</i>	Go to <i>Step 4</i>
2	Check the speakers, the rear deck, and the trunk area for damage, rattles, or vibration. Is there anything loose or in the way of the speaker causing the distortion?		Go to <i>Step 3</i>	Go to <i>Step 4</i>
3	Make the necessary repairs to secure the component causing the distortion. Is the repair complete?		System OK	
4	1. Disconnect the rear speakers. 2. Using an ohmmeter, test the speaker wires for a short to ground. Does the ohmmeter show the specified value?	∞	Go to <i>Step 6</i>	Go to <i>Step 5</i>

Step	Action	Value(s)	Yes	No
5	Repair the short circuit between the rear speaker connector and the radio connector. Is the repair complete?		System OK	
6	Substitute a known good speaker for the speaker causing the distortion. Is the distortion eliminated?		Go to <i>Step 7</i>	Go to <i>Step 8</i>
7	Replace the speaker. Is the repair complete?		System OK	
8	Replace the radio. Is the repair complete?		System OK	

ANTENNA

Power Antenna Does Not Work

Step	Action	Value(s)	Yes	No
1	Check fuse EF29. Is fuse EF29 blown?		Go to <i>Step 2</i>	Go to <i>Step 3</i>
2	1. Check for a short circuit and repair if necessary. 2. Replace the blown fuse. Is the repair complete?		System OK	
3	Use a voltmeter to test for battery voltage at fuse EF29. Does the battery voltage match the specified value?	11–14 v	Go to <i>Step 5</i>	Go to <i>Step 4</i>
4	Repair the open power supply circuit to fuse EF29. Is the repair complete?		System OK	
5	Use a voltmeter to test for battery voltage at power antenna connector terminal 1. Does the battery voltage match the specified value?	11–14 v	Go to <i>Step 7</i>	Go to <i>Step 6</i>
6	Repair the open circuit between power antenna connector terminal 1 and fuse EF29. Is the repair complete?		System OK	
7	Use an ohmmeter to test the ground circuit at power antenna connector terminal 2. Does the resistance match the specified value?	0 – 0.5 Ω	Go to <i>Step 9</i>	Go to <i>Step 8</i>
8	Repair the open ground circuit between power antenna connector terminal 2 and ground G303. Is the repair complete?		System OK	
9	1. Turn the ignition ON. 2. Turn the radio ON. 3. Use a voltmeter to test for battery voltage at power antenna connector terminal 3. Does the battery voltage match the specified value?	11–14 v	Go to <i>Step 10</i>	Go to <i>Step 11</i>
10	Replace the power antenna. Is the repair complete?		System OK	
11	1. Turn the ignition ON. 2. Turn the radio ON. 3. Use a voltmeter to test for battery voltage at radio terminal 12. Is the repair complete?	11–14 v	Go to <i>Step 12</i>	Go to <i>Step 13</i>

Step	Action	Value(s)	Yes	No
12	Repair the open circuit between radio terminal 12 and power antenna connector terminal 3. Is the repair complete?		System OK	
13	Replace the audio system. Is the repair complete?		System OK	

MAINTENANCE AND REPAIR

ON-VEHICLE SERVICE

STEREO CASSETTE AM/FM RADIO

Removal Procedure

1. Disconnect the negative battery cable.
2. Remove the audio system trim plate screws and the audio system trim plate.

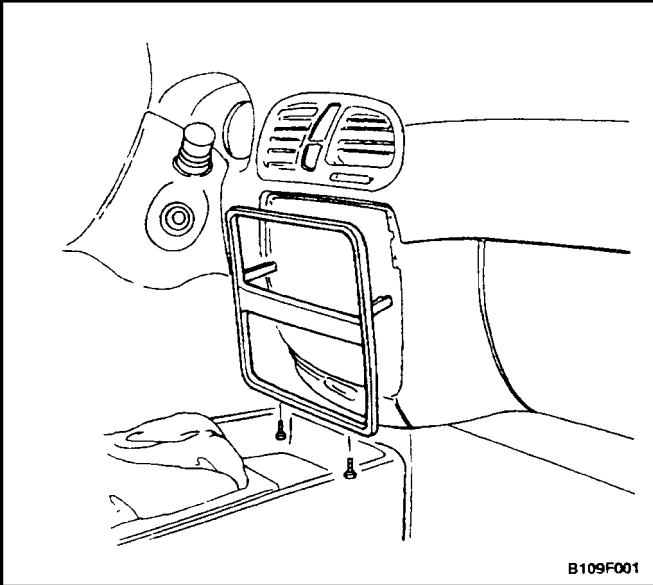

3. Remove the audio system bolts and the audio system.
4. Disconnect the audio system electrical connector and the antenna cable.

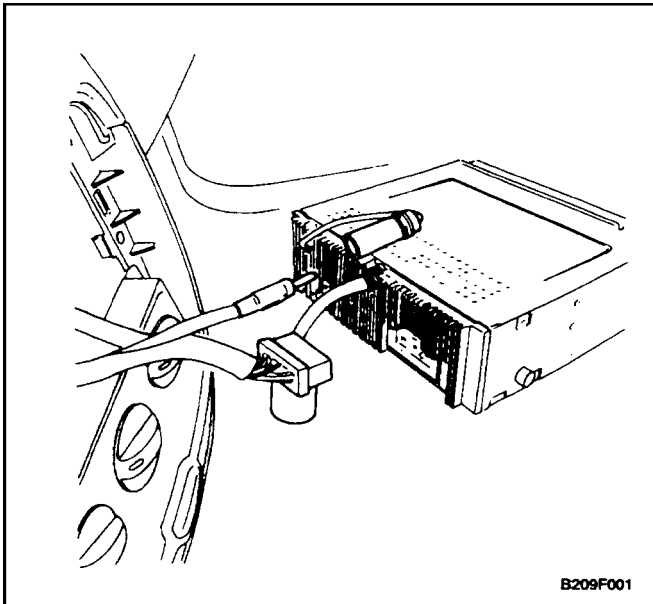

Installation Procedure

1. Connect the audio system electrical connector and the antenna cable.

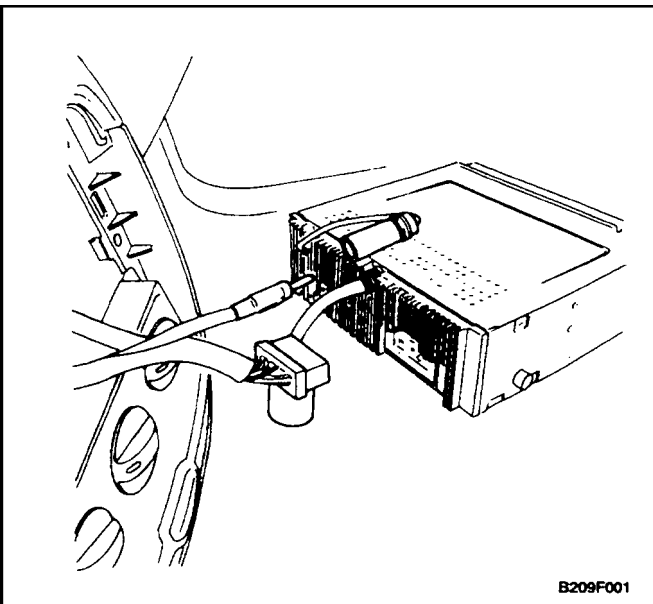

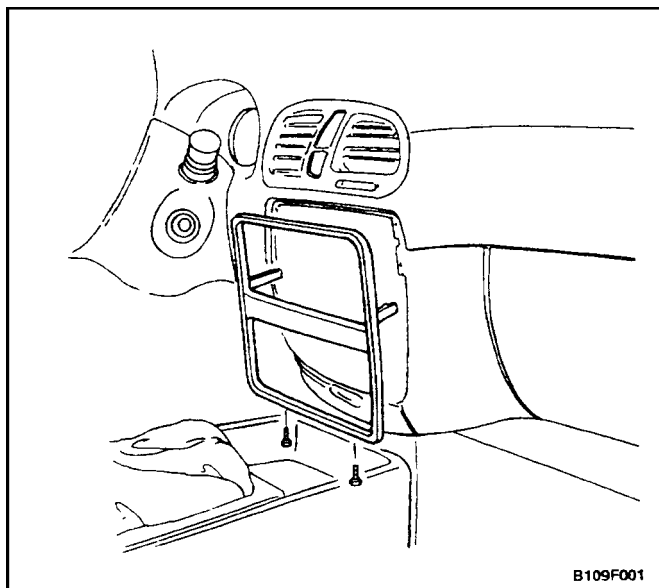

B109F001

2. Install the audio system with the bolts.

Tighten

Tighten the audio system bolts to 4 N•m (35 lb–in).

3. Install the audio system trim plate with the screws.
4. Connect the negative battery cable.
5. Enter the security code. Refer to "Audio Security Sys-tem" in this section.

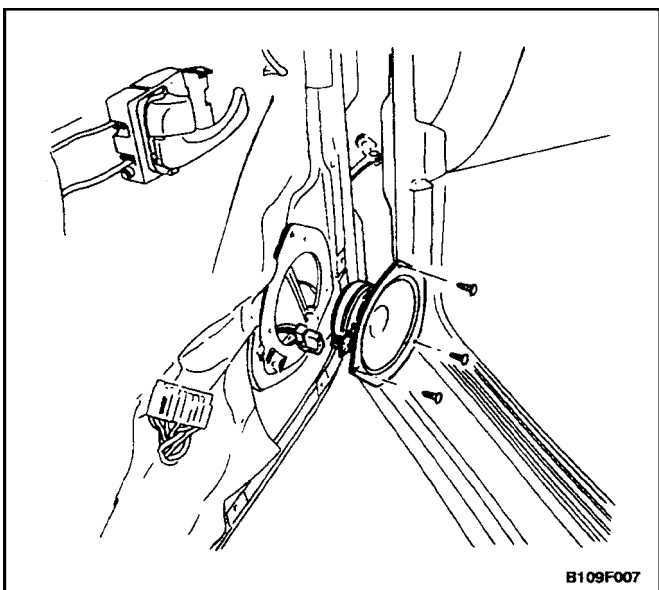

B109F007

FRONT DOOR SPEAKERS

Removal Procedure

1. Disconnect the negative battery cable.
2. Remove the front door trim panel. Refer to *section 9G, Interior Trim*.
3. Remove the front door speaker screws and the front door speaker.
4. Disconnect the electrical connector.

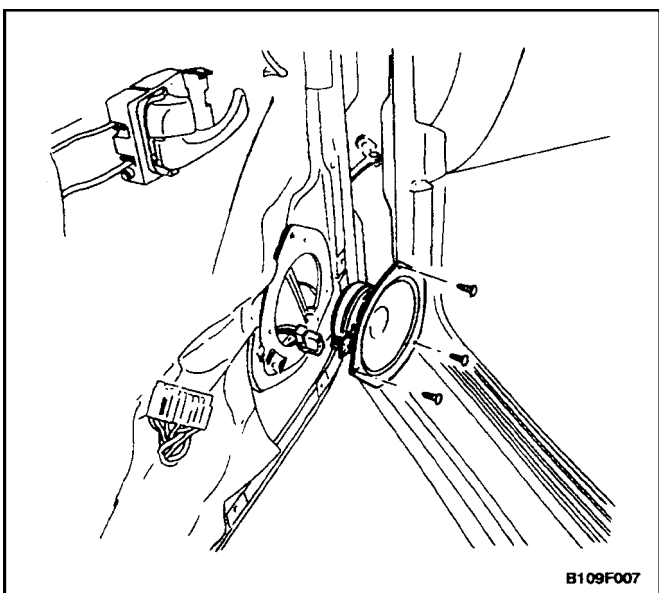

B109F007

Installation Procedure

1. Connect the electrical connector.
2. Install the front door speaker with the screws.

Tighten

Tighten the front door speaker screws to 4 N•m (35 lb–in).

3. Install the front door trim panel. Refer to *section 9G, Interior Trim*.
4. Connect the negative battery cable.

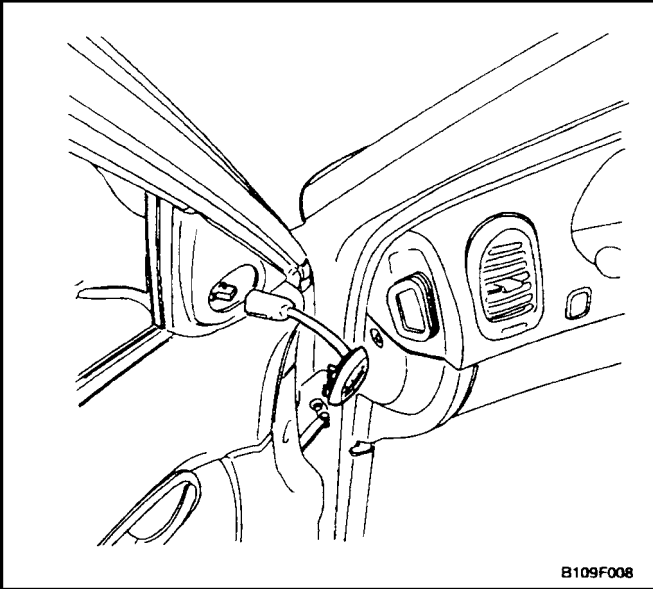

TWEETER SPEAKERS

Removal Procedure

1. Disconnect the negative battery cable.
2. Remove the tweeter speaker by prying the tweeter speaker off of the front door eschutcheon.
3. Disconnect the electrical connector.

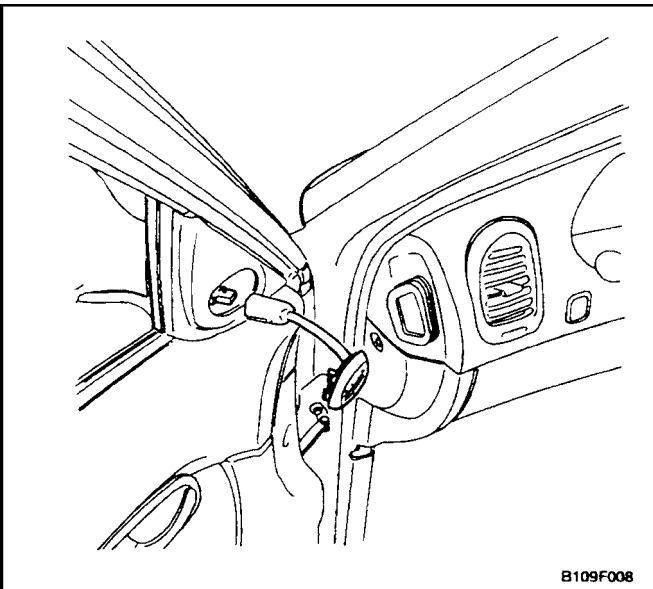

Installation Procedure

1. Connect the electrical connector.
2. Install the tweeter speaker by snapping the tweeter speaker onto the front door eschutcheon.
3. Connect the negative battery cable.

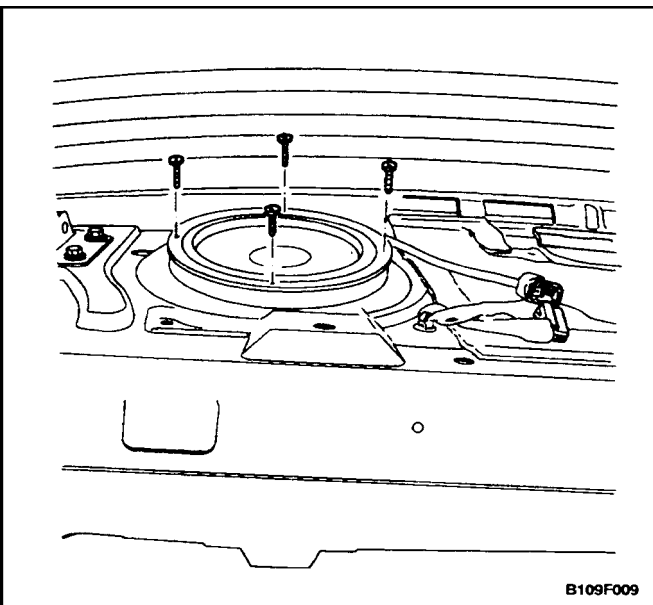

REAR SPEAKERS (NOTCHBACK)

Removal Procedure

1. Disconnect the negative battery cable.
2. Remove the rear seat cushion and the rear seat-back. Refer to *Section 9H, Seats*.
3. Remove the right side C-pillar trim panel and the deck lid sill plate trim cover. Refer to *section 9G, Interior Trim*.
4. Disconnect the electrical connector.
5. Remove the screws and the rear speakers.

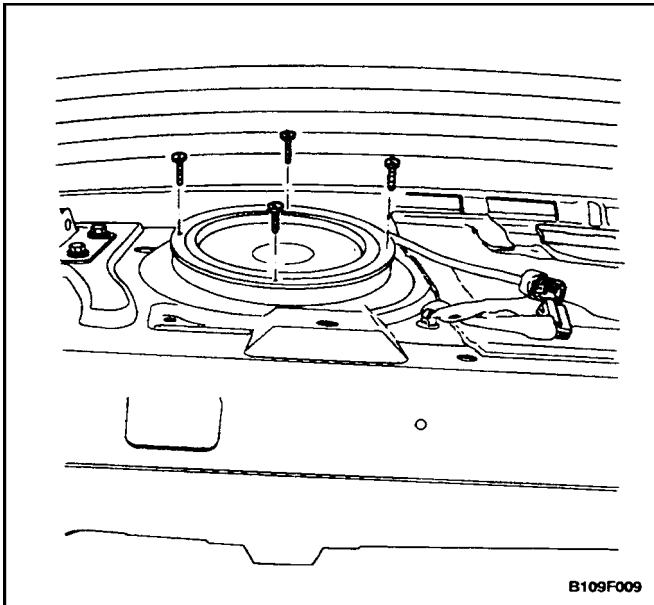

Installation Procedure

1. Install the rear speakers with the screws.

Tighten

Tighten the rear speaker screws to 4 N•m (35 lb-in).

2. Connect the electrical connector.
3. Install the deck lid sill plate trim cover and the right side C-pillar trim panel. Refer to section 9G, *Interior Trim*.
4. Install the rear seatback and the rear seat cushion. Refer to Section 9H, *Seats*.
5. Connect the negative battery cable.

REAR SPEAKERS (HATCHBACK)

Removal Procedure

1. Disconnect the negative battery cable.
2. Remove the rear speaker access cover.
3. Remove the screws and the rear speaker.
4. Disconnect the electrical connector.

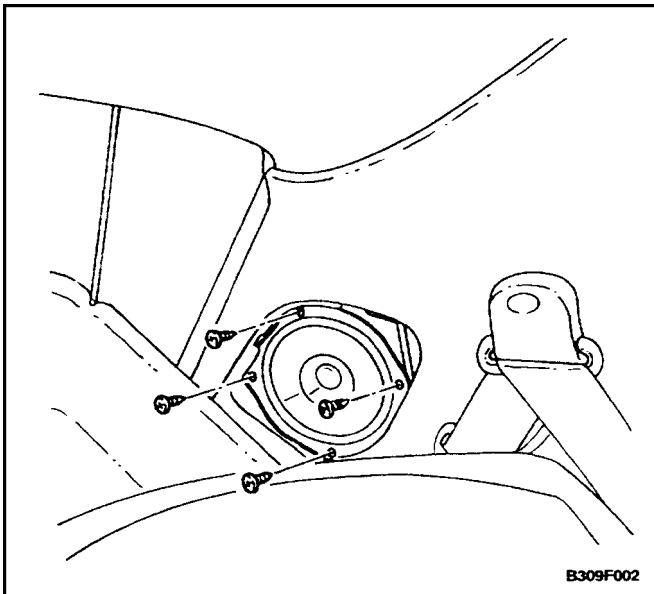

Installation Procedure

1. Connect the electrical connector.

Notice : Dissimilar metals in direct contact with each other may corrode rapidly. Make sure to use the correct fasteners to prevent premature corrosion.

2. Install the rear speaker with the screws.

Tighten

Tighten the rear speaker screws to 4 N•m (35 lb-in).

3. Install the rear speaker access cover.
4. Connect the negative battery cable.

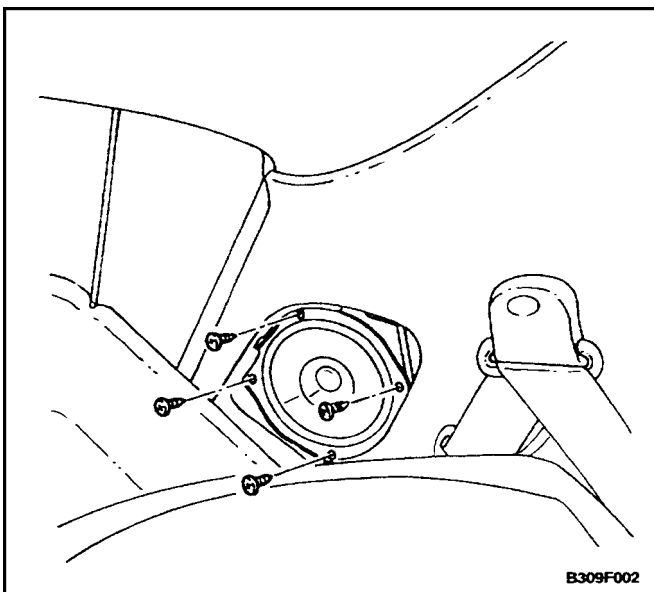

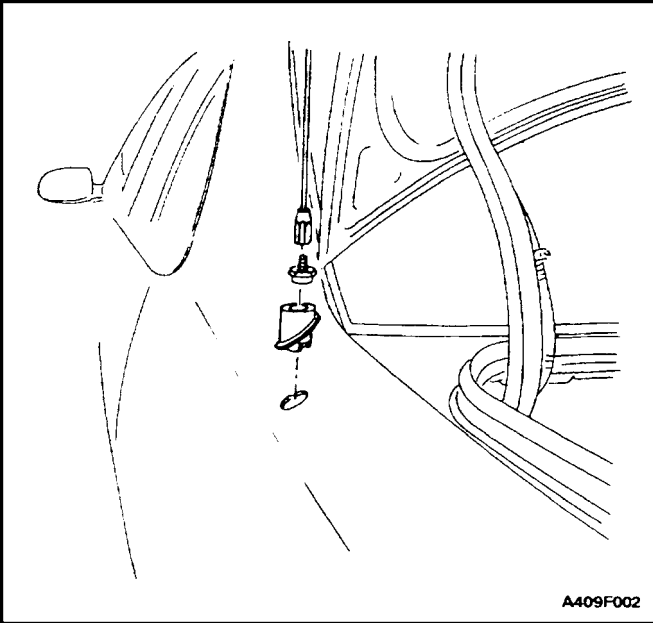

MAST ANTENNA

Removal Procedure

1. Disconnect the negative battery cable.
2. Remove the luggage compartment rear quarter trim panel. Refer to *Section 9G, Interior Trim*.
3. Unscrew and remove the mast antenna.
4. Remove the antenna cap nut and the rubber grommet.

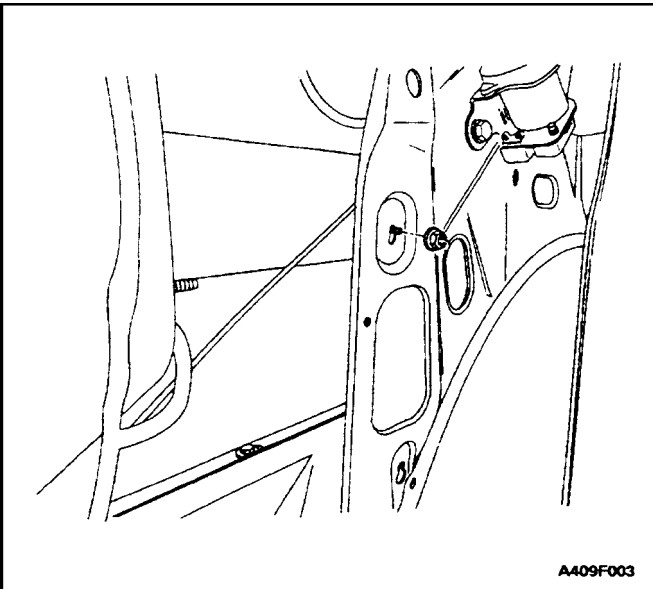

Installation Procedure

Notice : Dissimilar metals in direct contact with each other may corrode rapidly. Make sure to use the correct fasteners to prevent premature corrosion.

1. Install the mast antenna base with the nut.

Tighten

Tighten the mast antenna base nut to 4 N•m (35 lbin).

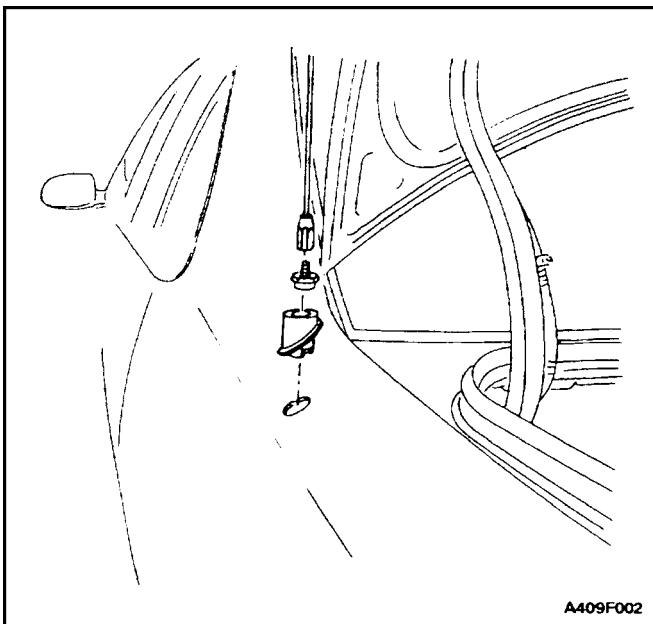

2. Connect the antenna cable.
3. Install the rubber grommet and the antenna cap nut.

Tighten

Tighten the antenna cap nut to 7 N•m (62 lb-in).

4. Install the mast antenna.
5. Install the luggage compartment rear quarter trim panel. Refer to *Section 9G, Interior Trim*.
6. Connect the negative battery cable.

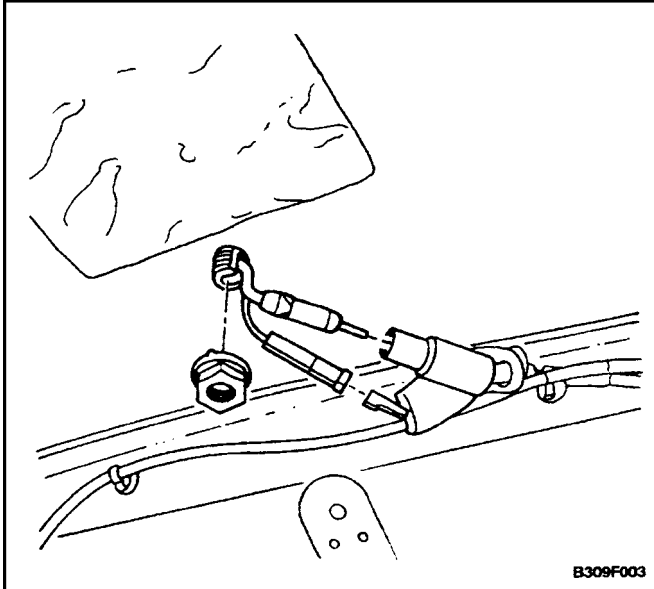

ROOF ANTENNA

(Wagon Shown, Hatchback Similar)

Removal Procedure

1. Disconnect the negative battery cable.
2. Remove the formed headliner. Refer to *Section 9Q, Roof*.
3. Disconnect the antenna cable and the electrical connector.
4. Remove the nut and the antenna.

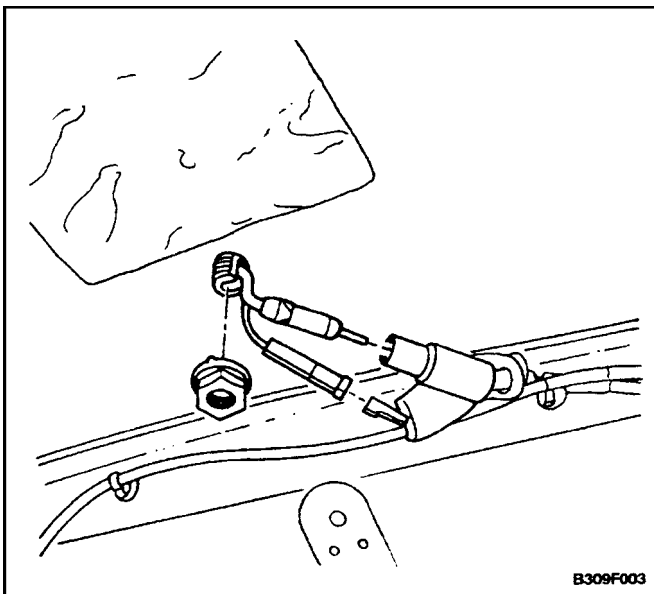

Installation Procedure

Notice : Dissimilar metals in direct contact with each other may corrode rapidly. Make sure to use the correct fasteners to prevent premature corrosion.

1. Install the roof antenna with the nut.

Tighten

Tighten the roof antenna nut to 10 N•m (89 lb-in).

2. Connect the antenna cable and the electrical connector.
3. Install the formed headliner. Refer to *Section 9Q, Roof*.
4. Connect the negative battery cable.

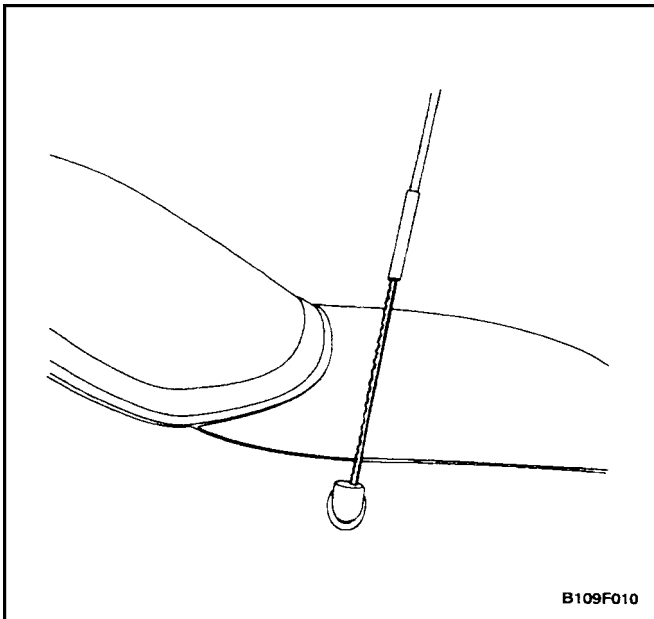

POWER ANTENNA MAST(NOTCHBACK)

Removal Procedure

1. Remove the antenna cap nut and the rubber grommet.
2. Turn on the radio and remove the antenna mast and cable.
3. Turn off the radio.

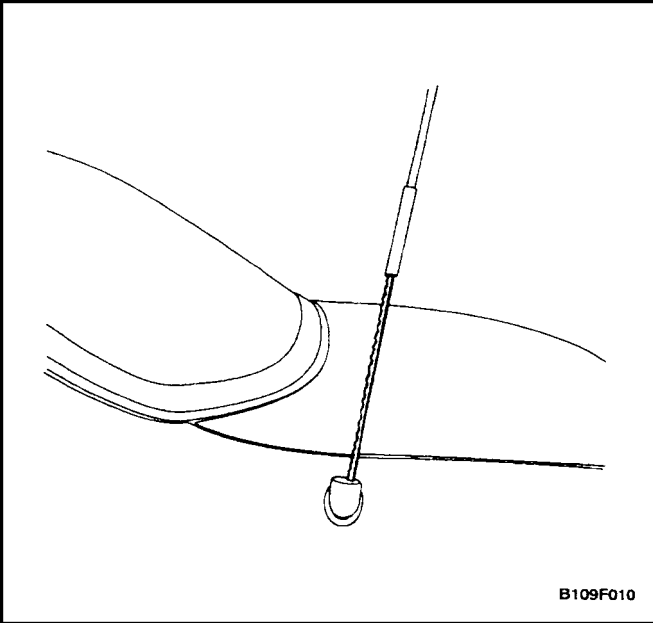

B109F010

Installation Procedure

1. Install the antenna mast with the teeth of the cable facing the front of the vehicle.
2. Install the rubber grommet and the antenna cap nut.

Tighten

Tighten the antenna cap nut to 7 N•m (62 lb-in).

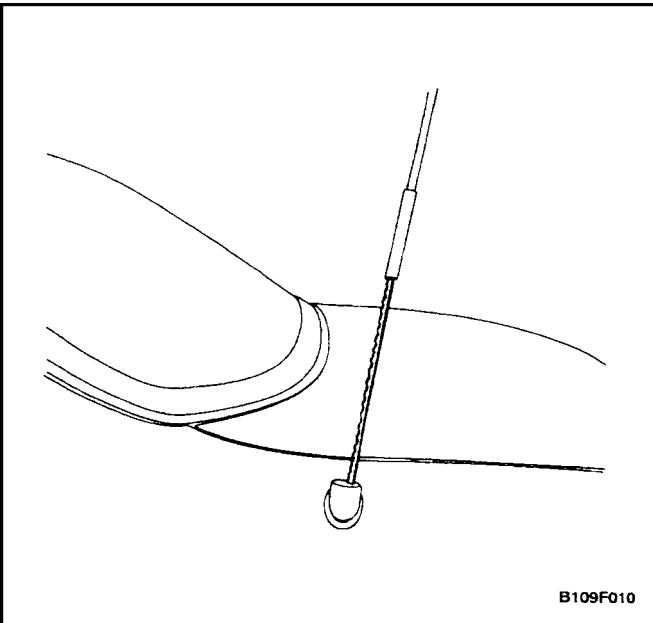

B109F010

POWER ANTENNA MOTOR (NOTCHBACK)

Removal Procedure

1. Disconnect the negative battery cable.
2. Remove the luggage compartment rear quarter trim panel. Refer to *Section 9G, Interior Trim*.
3. Remove the antenna cap nut and the rubber grommet.

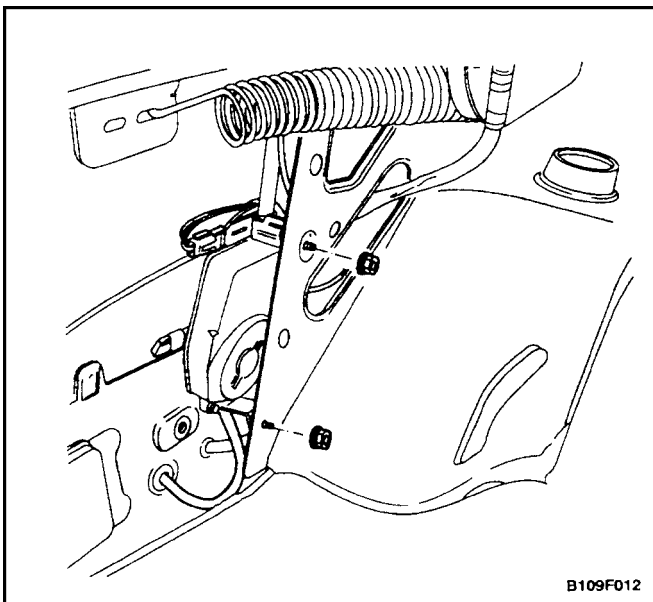

B109F012

4. Loosen the nuts securing the antenna motor to the vehicle.
5. Remove the antenna motor.
6. Disconnect the electrical connector and the drain hose from the antenna motor.

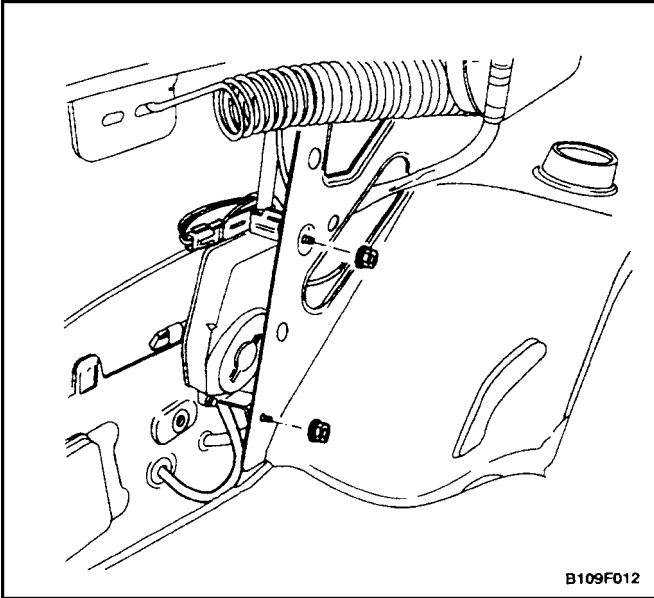

Installation Procedure

1. Connect the electrical connector and the drain hose to the antenna motor.
2. Install the antenna motor with the nuts.

Tighten

Tighten the antenna motor nuts to 7 N•m (62 lb-in).

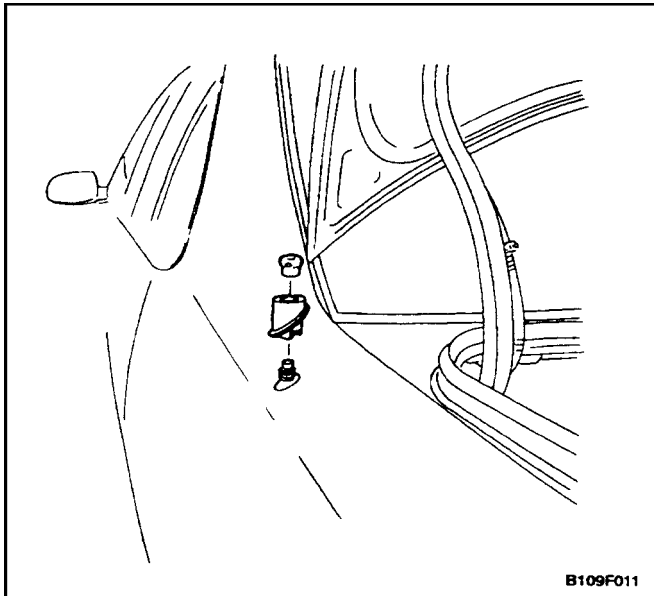

3. Install the antenna cap nut.
4. Install the luggage compartment rear quarter trim panel. Refer to Section 9G, Interior Trim.

Tighten

Tighten the antenna cap nut to 7 N•m (62 lb-in).

5. Connect the negative battery cable.

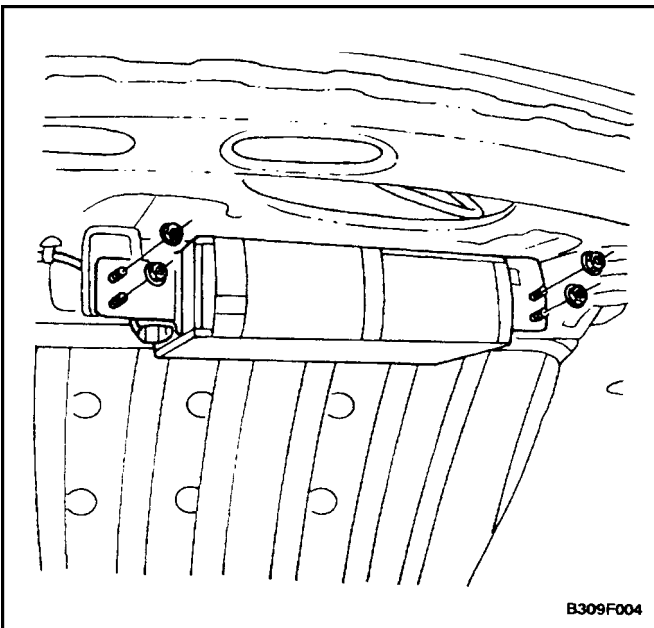

COMPACT DISC CHANGER

Removal Procedure

1. Disconnect the negative battery cable.
2. Disconnect the CD changer electrical connector.
3. Remove the nuts and the CD changer.

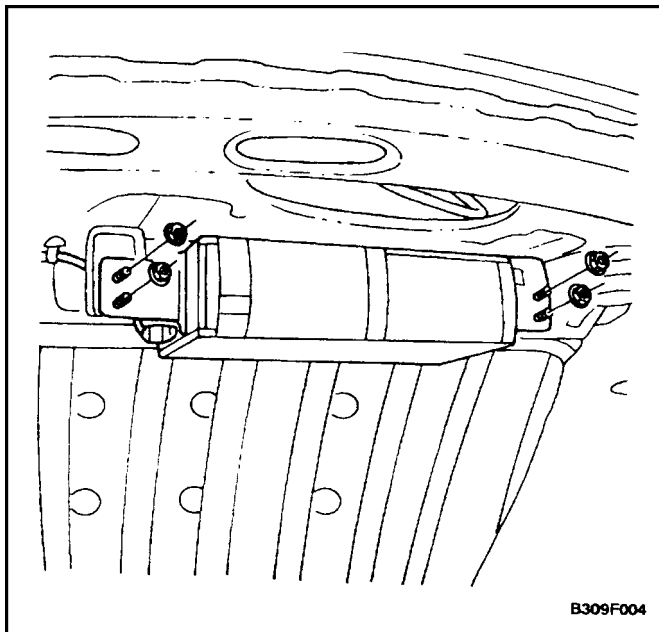

Installation Procedure

1. Install the CD changer with the nuts.

Tighten

Tighten the CD changer nuts to 7 N•m (62 lb-in).

2. Connect the CD changer electrical connector.
3. Connect the negative battery cable.

GENERAL DESCRIPTION AND SYSTEM OPERATION

AUDIO SYSTEMS

There are three audio systems available:

- Stereo digital logic cassette AM/FM radio with electronic tape ejection.
- Stereo digital logic AM/FM radio with CD player.
- Trunk mounted CD changer which is available with the cassette AM/FM radio.

AUDIO SECURITY SYSTEM

The audio security system is activated whenever the audio system circuit is disconnected from the battery. A four-digit security code must be entered in order for the audio system to resume functioning. The security code is stamped on a card located in the vehicle (usually in the glove box). The following security code entering procedure must be used to deactivate the audio security system:

1. After connecting the audio security system to the battery, "COdE" will flash on the display.
2. Enter the proper security number into the unit, using the preset buttons No. 1 through 8. For example, if the security number is "1234":
 - 1) Press the preset button No. 1. "COdE": will disappear and "1—" will appear on the display.
 - 2) Press the preset button No. 2, and "12—" will appear.
 - 3) Press the preset button No. 3, and "123—" will appear.
 - 4) Press the preset button No. 4, and "1234" will appear.
1. The audio system will function and will transfer to the radio.

If you fail to enter the correct security number into the unit, "Err" will appear followed by "COdE" and there will be several audible beeps. If this happens, repeat the security entering procedure beginning with step 2.

FRONT AND REAR SPEAKERS

All audio systems use four speakers: two speakers mounted in the front doors and two speakers mounted in the rear. A coaxial two-way rear speaker is offered as an option.

TWEETER SPEAKERS

The tweeter speakers are mounted on the front door es-chutcheon next to the dash panel.

MAST ANTENNA

The manual antenna is designed to withstand most car washes without damage. If the mast becomes slightly bent, it can be straightened by hand. The manual antenna can be replaced if it is severely bent. Manual antennas must be kept clean for good performance.

POWER ANTENNA

The optional power antenna is controlled by the radio. When the radio power is turned on, the antenna is extended. When the radio is turned off, either by turning the power off or by turning the ignition off, the antenna is retracted.

ROOF ANTENNA

The two-piece roof antenna is standard equipment on the hatchback and the wagon. The top half of the antenna can be unscrewed and removed if height clearance problems occur.

TAPE PLAYER AND CASSETTE CARE

The head and the capstan are the two parts of the tape player that should be cleaned. To clean the head and the capstan, use a cotton swab dipped in rubbing alcohol. A cassette cleaning kit may also be used to clean the head and the capstan. Follow the cleaning kit instructions to clean the tape player. This service should be performed every 100 hours of cassette operation.

Do not touch the tape head with magnetized tools. If the head becomes magnetized, it will degrade cassettes played in the player. No service is performed on the cassettes. The cassette manufacturer handles warranties of the cassettes. Store cassettes away from extreme heat and direct sunlight.

COMPACT DISC CARE

Handle discs carefully. Store the discs in protective cases away from the sun, heat, and dust. If the surface is soiled, dampen a clean, soft cloth in a solution of mild neutral detergent and wipe the disc clean.

SECTION : 9A

BODY WIRING SYSTEM

CAUTION : *Disconnect the negative battery cable before removing or installing any electrical unit or when a tool or equipment could easily come in contact with exposed electrical terminals. Disconnecting this cable will help prevent personal injury and damage to the vehicle. The ignition must also be in LOCK unless otherwise noted..*

TABLE OF CONTENTS

SCHEMATIC AND ROUTING DIAGRAMS	9A-1	FUSE CHART	9A-5
WIRE COLOR CHART	9A-1	REAR HARNESS ROUTING	9A-7
POWER DISTRIBUTION SCHEMATIC	9A-2	FRONT HARNESS ROUTING	9A-8
FUSE BLOCK LOCATOR (ENGINE)	9A-4	FLOOR HARNESS ROUTING	9A-9
FUSE BLOCK LOCATOR (PASSENGER COMPARTMENT)	9A-4	INSTRUMENT HARNESS ROUTING	9A-10
		DOOR HARNESS ROUTING	9A-11

SCHEMATIC AND ROUTING DIAGRAMS

WIRE COLOR CHART

Wire Color	Abbreviation On Schematic
Green	DK GRN
Light Green	LT GRN
Blue	DK BLU
Brown	BRN
Orange	ORN
Yellow	YEL
Grey	GRY
Sky Blue	LT BLU
Red	RED
Black	BLK
Pink	PNK
White	WHT
Purple	PPL

Wires With Tracers

Wire Color	Abbreviation On Schematic
Red with White Tracer	RED/WHT

POWER DISTRIBUTION SCHEMATIC

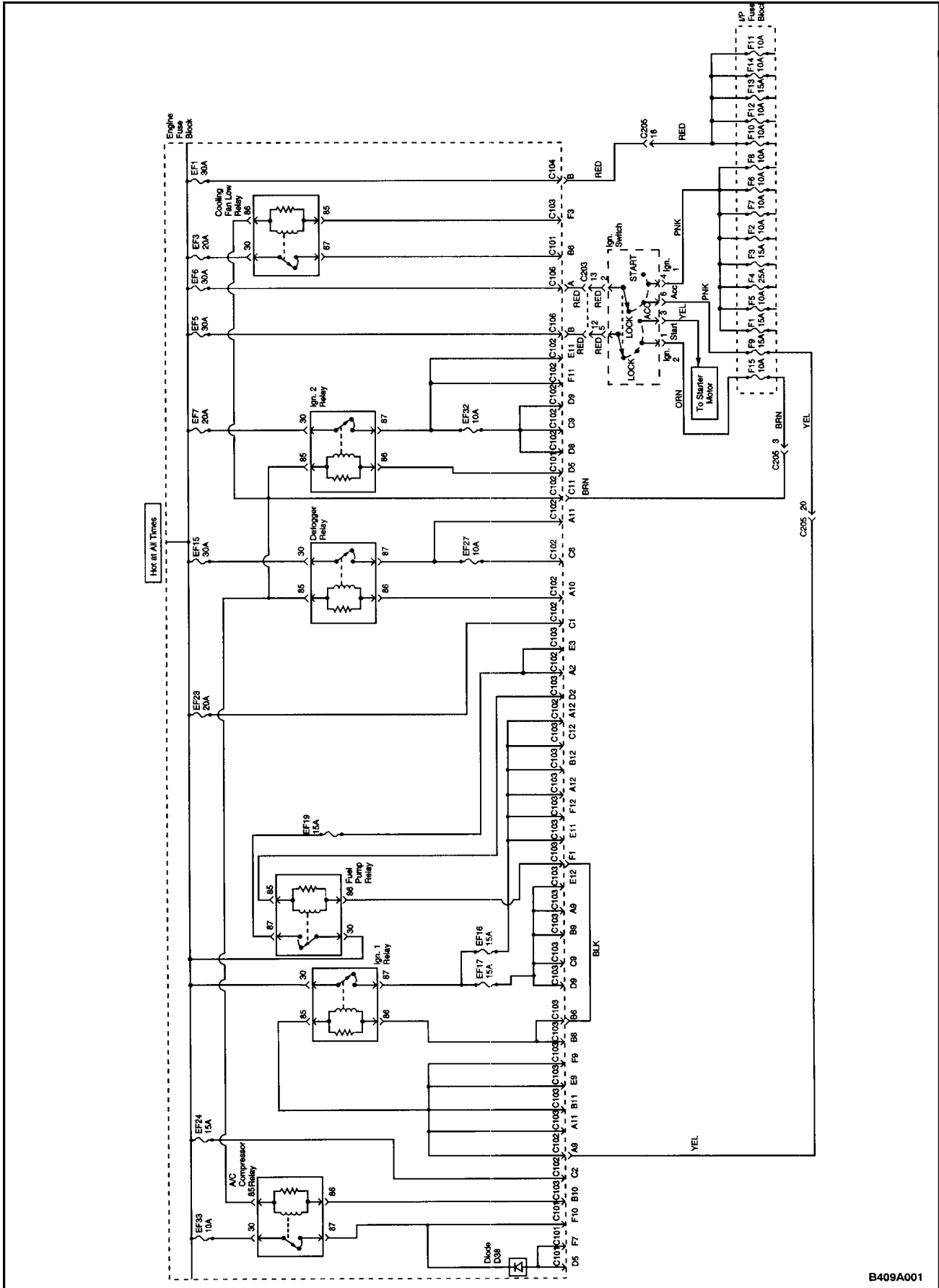

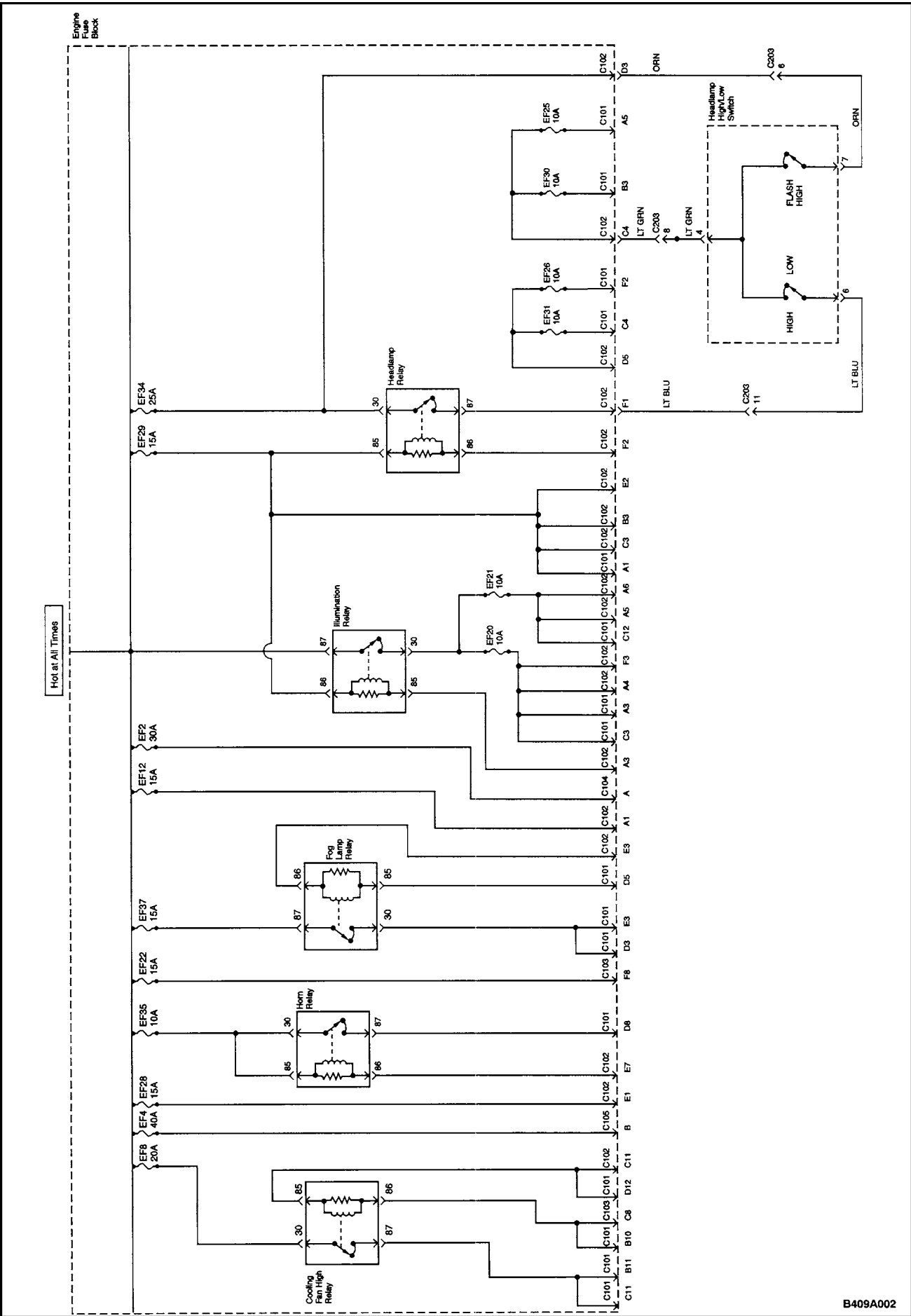

FUSE BLOCK LOCATOR (ENGINE)

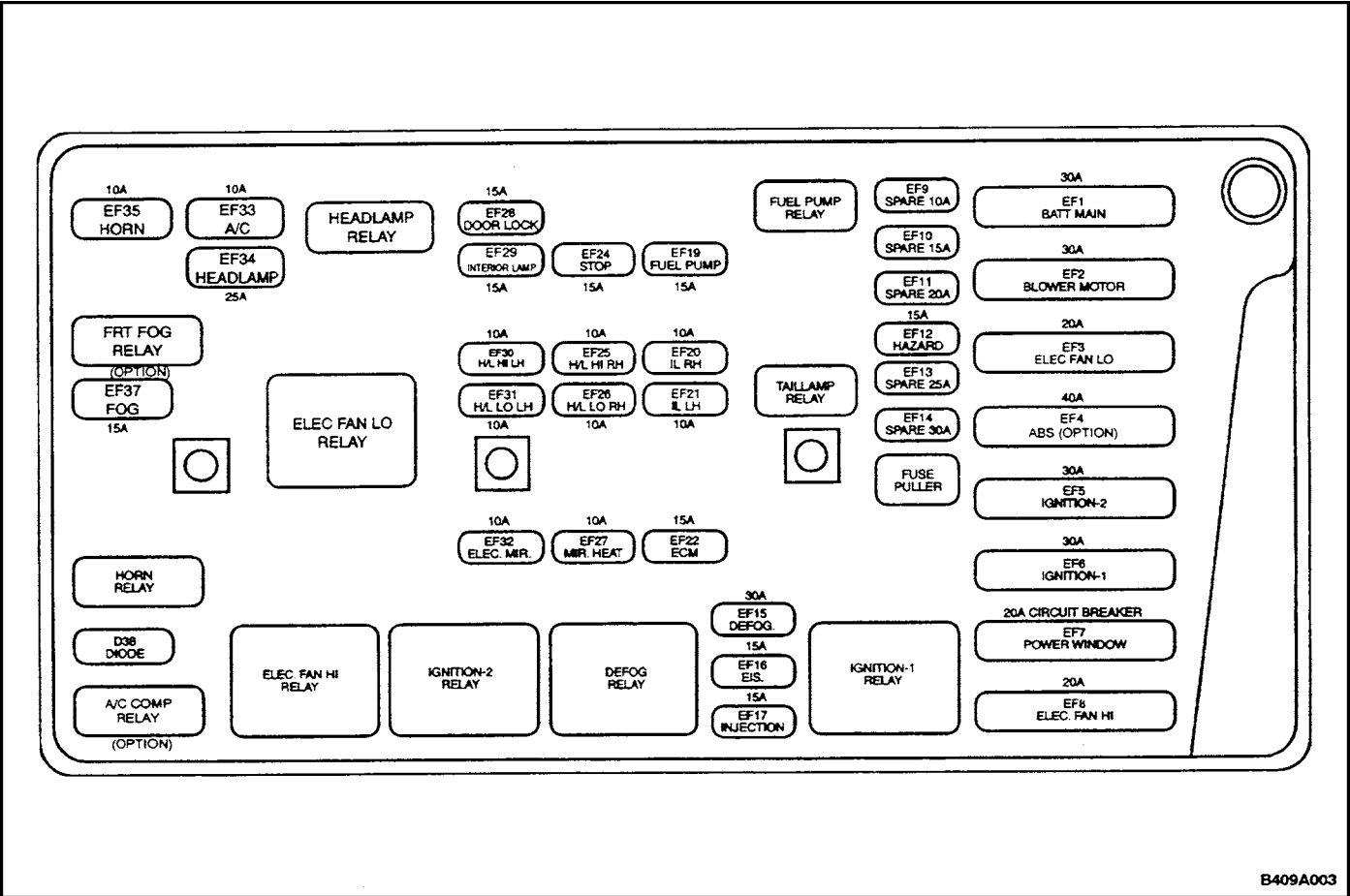

B409A003

FUSE BLOCK LOCATOR (PASSENGER COMPARTMENT)

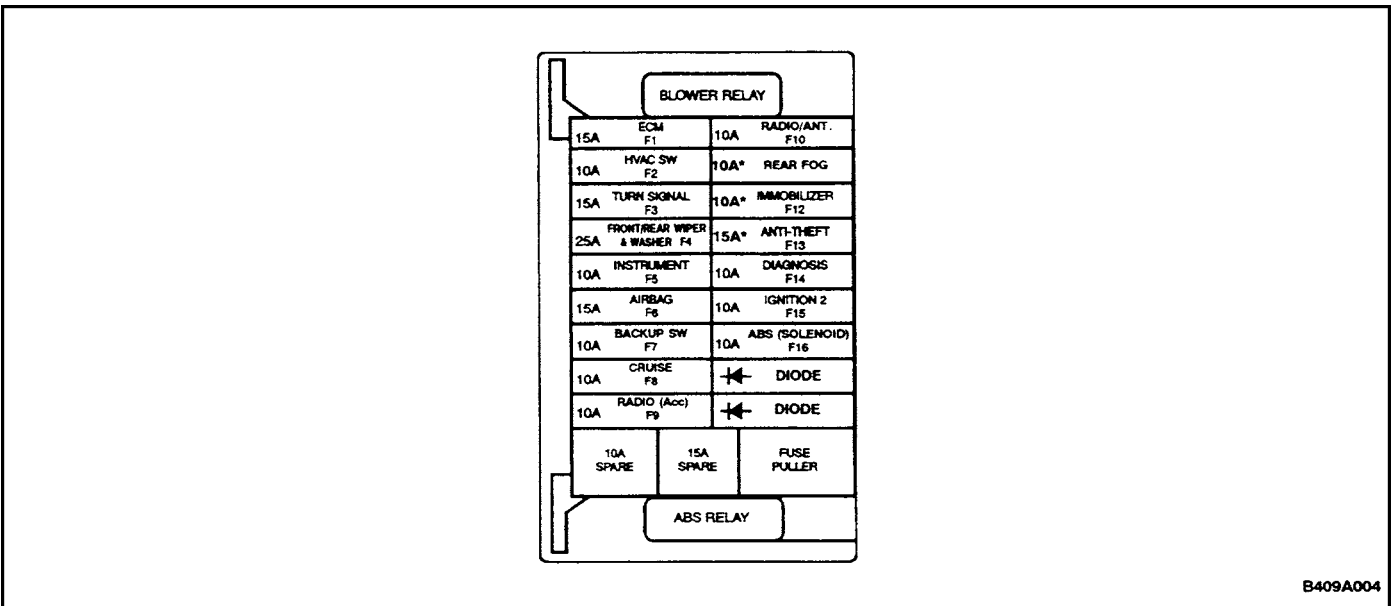

B409A004

FUSE CHART

Fuse	Rating/Source		Circuit
EF1 (Engine Fuse)	30A	B+	I/P Fuse Block, Engine Control Module
EF2	30A	B+	Blower Motor
EF3	20A	B+	Cooling Fan (Low) Relay, Cooling Fan
EF4	40A	B+	ABS Relay
EF5	30A	B+	Ign 2 (Ign Key)
EF6	30A	B+	Ign 1 (Ign Key)
EF7	20A	B+	Ign 2 Relay, EF32, Sun Roof, Power Windows
EF8	20A	B+	Cooling Fan (High) Relay, Cooling Fan Control Relay, Cooling Fan
EF12	15A	B+	Hazard Switch
EF15	30A	B+	Defogger Relay, EF27, Back Window Defogger
EF16	15A	B+	EVAP Solenoid, VGIS Solenoid, Generator Terminal F, Electronic Ignition System Coil
EF17	15A	B+	Injector 1, Injector 2, Injector 3, Injector 4
EF19	15A	B+	Fuel Pump
EF20	10A	B+	Parking Lamp, RH Taillamp
EF21	10A	B+	Parking Lamp, License Lamp, LH Taillamp
EF23	20A	B+	Cigar Lighter
EF24	15A	B+	Stoplamp Switch
EF25	10A	EF12	Headlamp High RH
EF26	10A	EF12	Headlamp Low RH
EF27	10A	EF32	Electric Outside Rearview Mirror Defogger
EF28	15A	B+	Auto Door Lock
EF29	15A	B+	Illumination Relay, Siren, Power Antenna, Luggage Compartment Lamp, Interior Courtesy Lamp, Headlamp Relay
EF30	10A	EF12	Headlamp High LH
EF31	10A	EF12	Headlamp Low LH
EF32	10A	EF7	Electric Outside Rearview Mirror, Keyless Entry System Unit

9A – 6 BODY WIRING SYSTEM

Fuse	Rating/Source		Circuit
EF33	10A	B+	A/C Compressor Relay, A/C Compressor, D38 (diode)
EF34	25A	B+	Headlamp Relay, EF30, EF25, EF31, EF26, High Headlamp Switch, Passenger Switch
EF35	10A	B+	Horn Switch and Horn
EF37	15A	B+	Fog Lamp Relay, Front Fog Lamps
F1 (Fuse)	15A	EF6	Ign 1 Relay, Engine Control Module, CMP
F2	10A	EF6	HVAC Switch
F3	15A	EF6	Hazard Switch/Turn Signal, Digital Clock
F4	25A	EF6	Wiper Switch, Intermittent Wiper Relay, Wiper Motor, Rear Wiper Motor, Rear Wiper Motor Switch
F5	10A	EF6	ABS Warning Lamp, Chime Module, Transmission Range Switch, Instrument Cluster. BTSI Solenoid
F6	10A	EF6	SIR System
F7	10A	EF6	Backup Switch
F8	10A	EF6	Cruise Control, Immobilizer
F9	15A	EF6	Radio, Key Interlock Solenoid, Cigarette Lighter
F10	10A	EF1	Instrument Cluster
F12	10A	EF1	Engine Immobilizer
F13	15A	EF1	Anti-Theft System
F14	10A	EF1	Data Link Connector
F15	10A	EF5	Ign 2 Relay, A/C Relay, Defogger Relay, ABS Relay, ABS EBCM

REAR HARNESS ROUTING

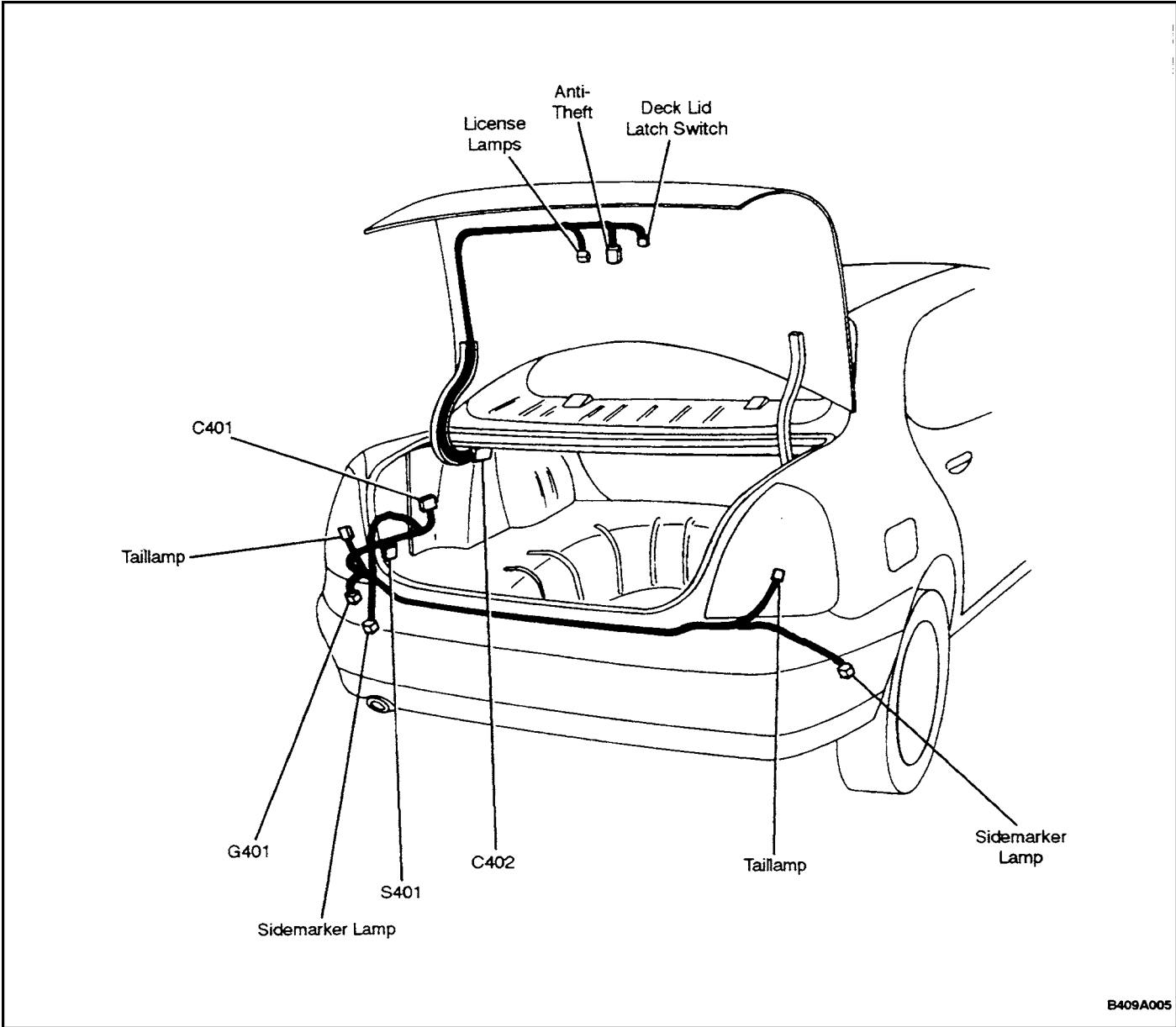

FRONT HARNESS ROUTING

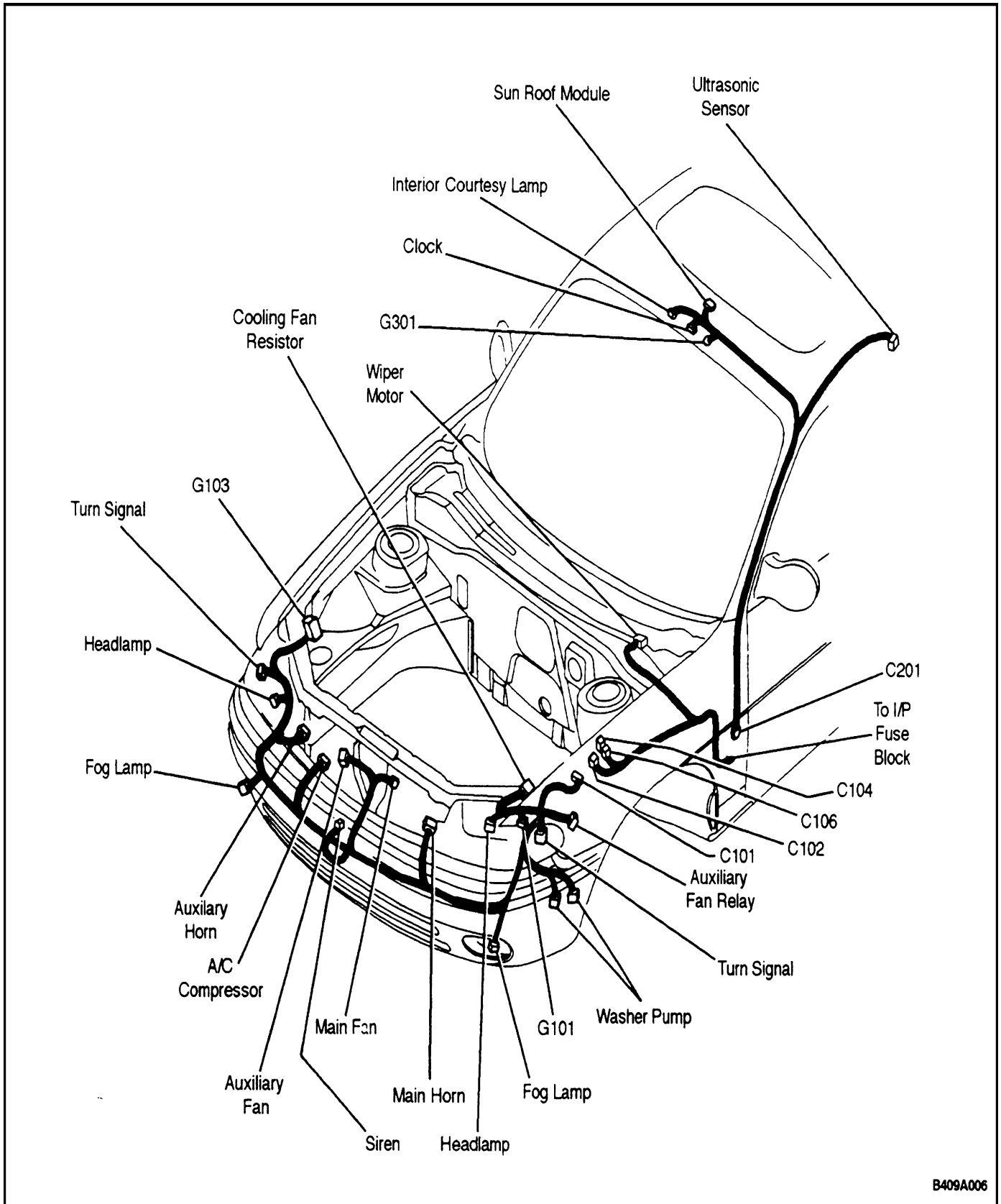

FLOOR HARNESS ROUTING

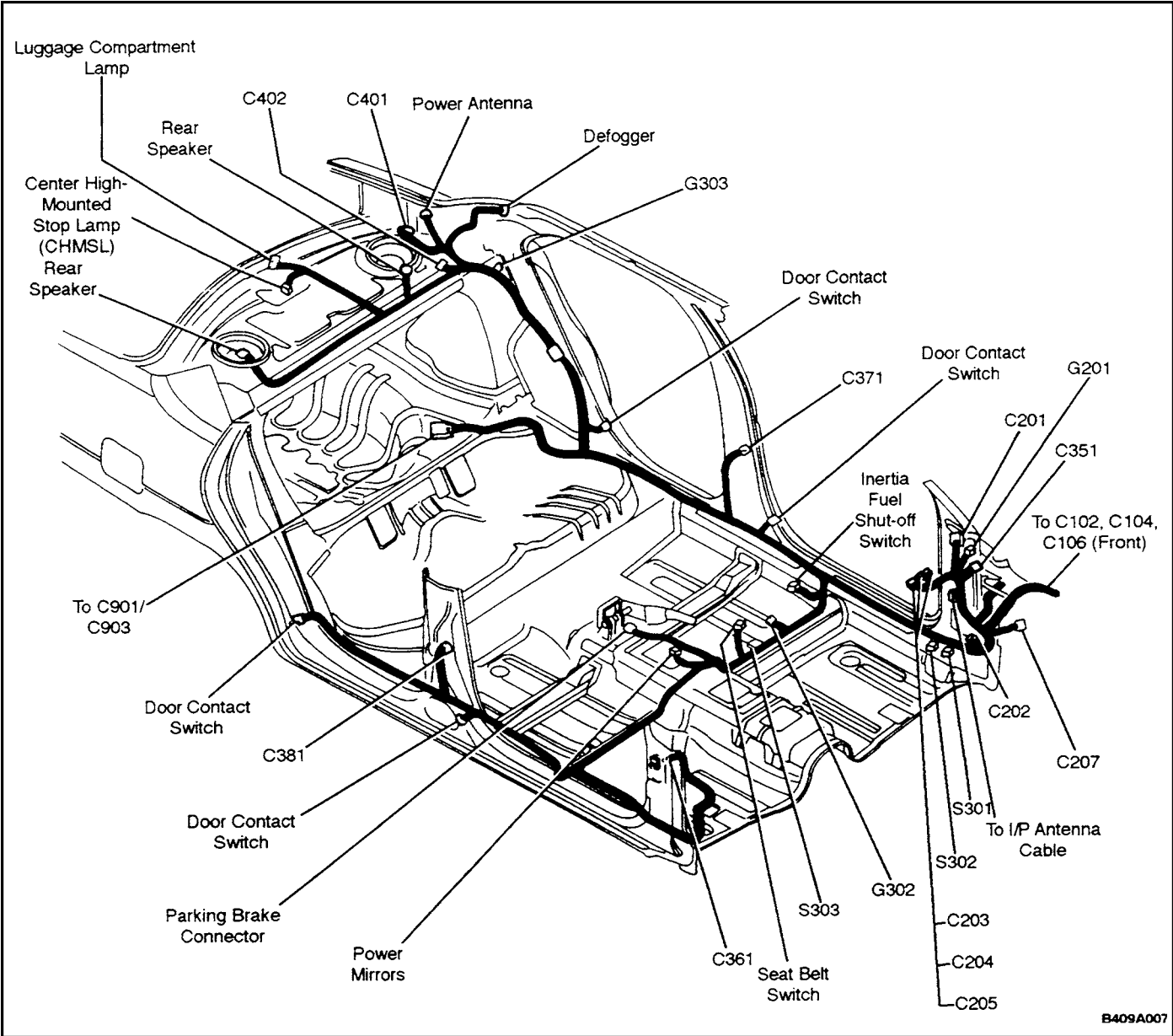

INSTRUMENT HARNESS ROUTING

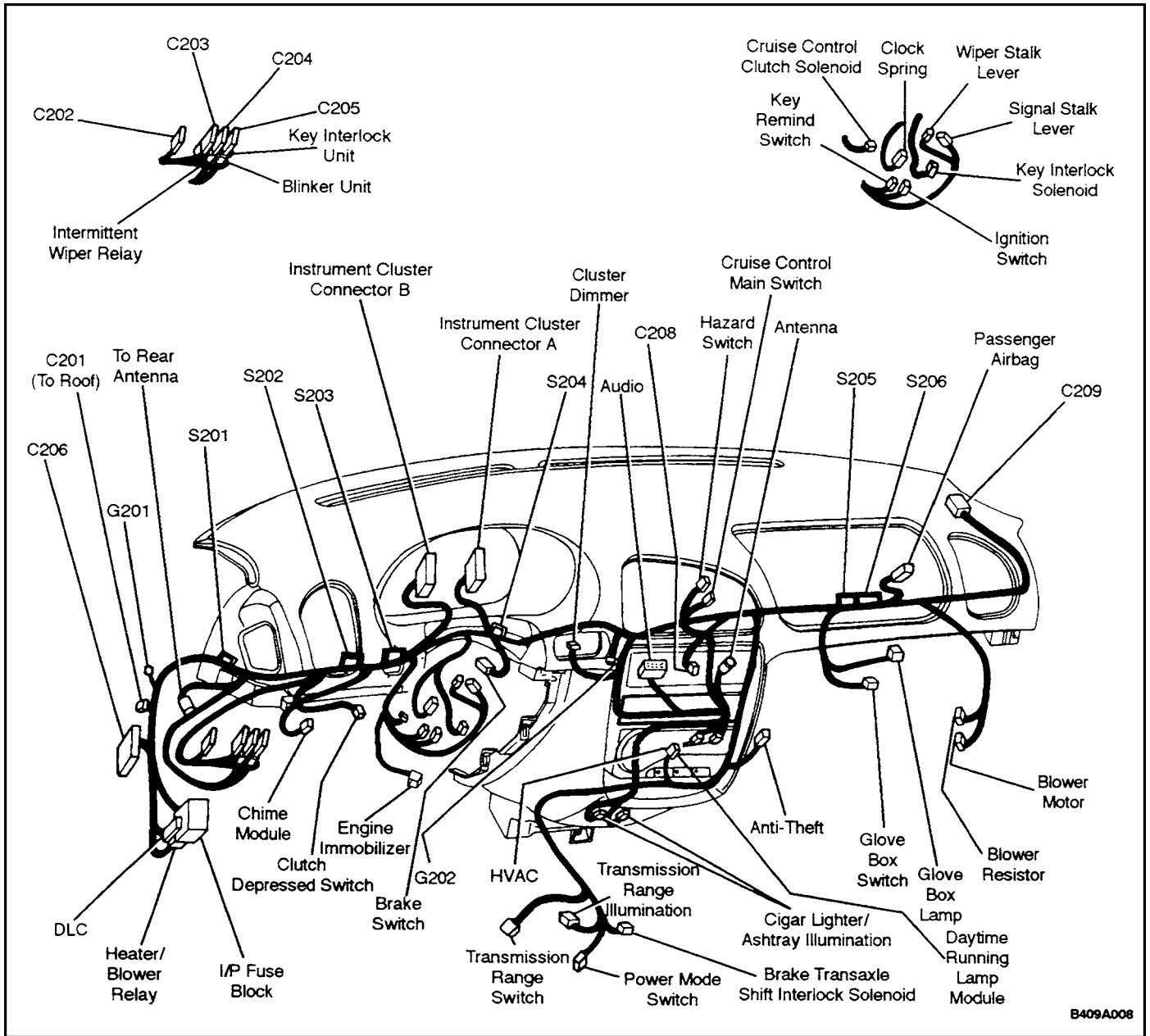

DOOR HARNESS ROUTING

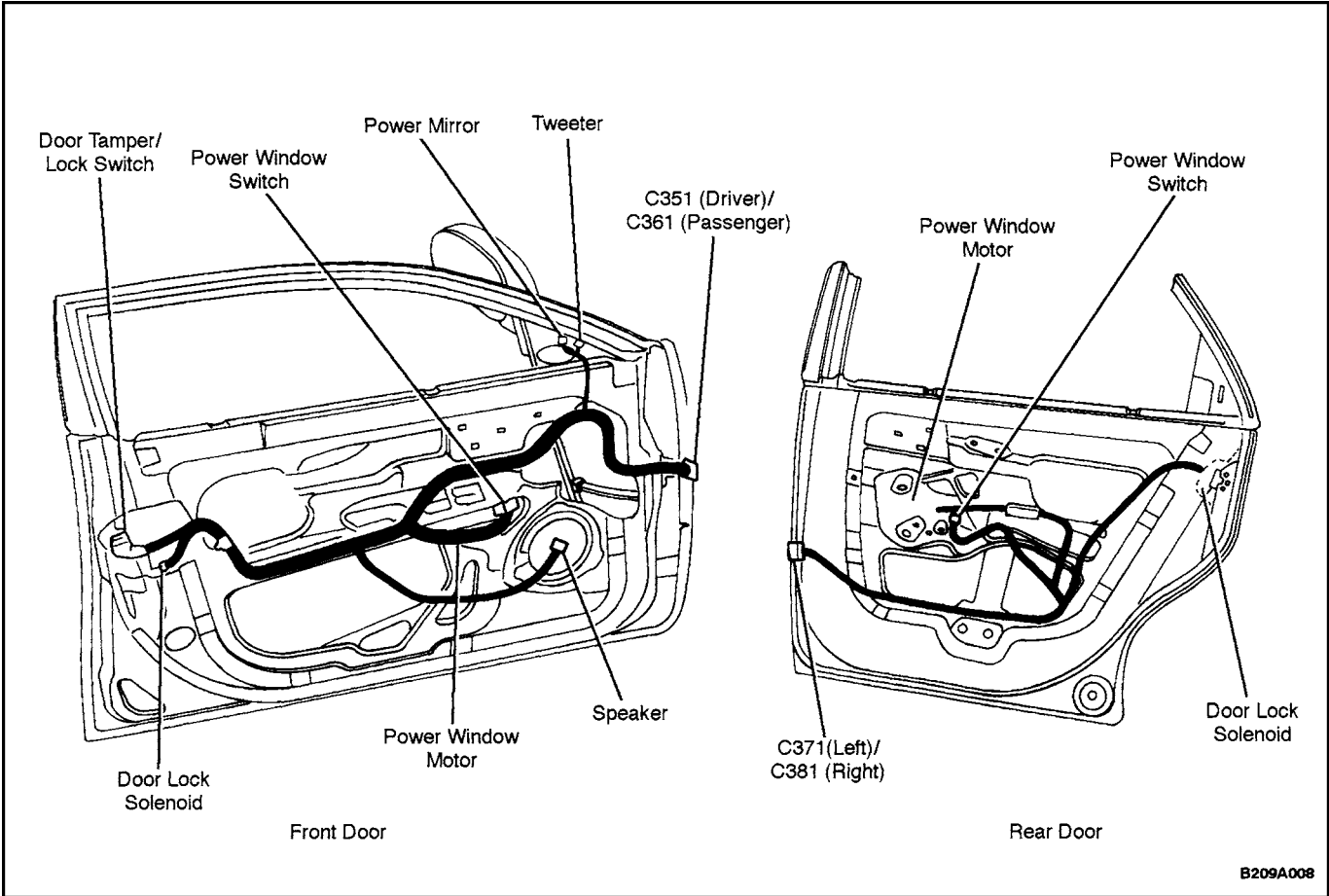

CRUISE CONTROL SYSTEM (MANUAL TRANSAXLE) (2 OF 2)

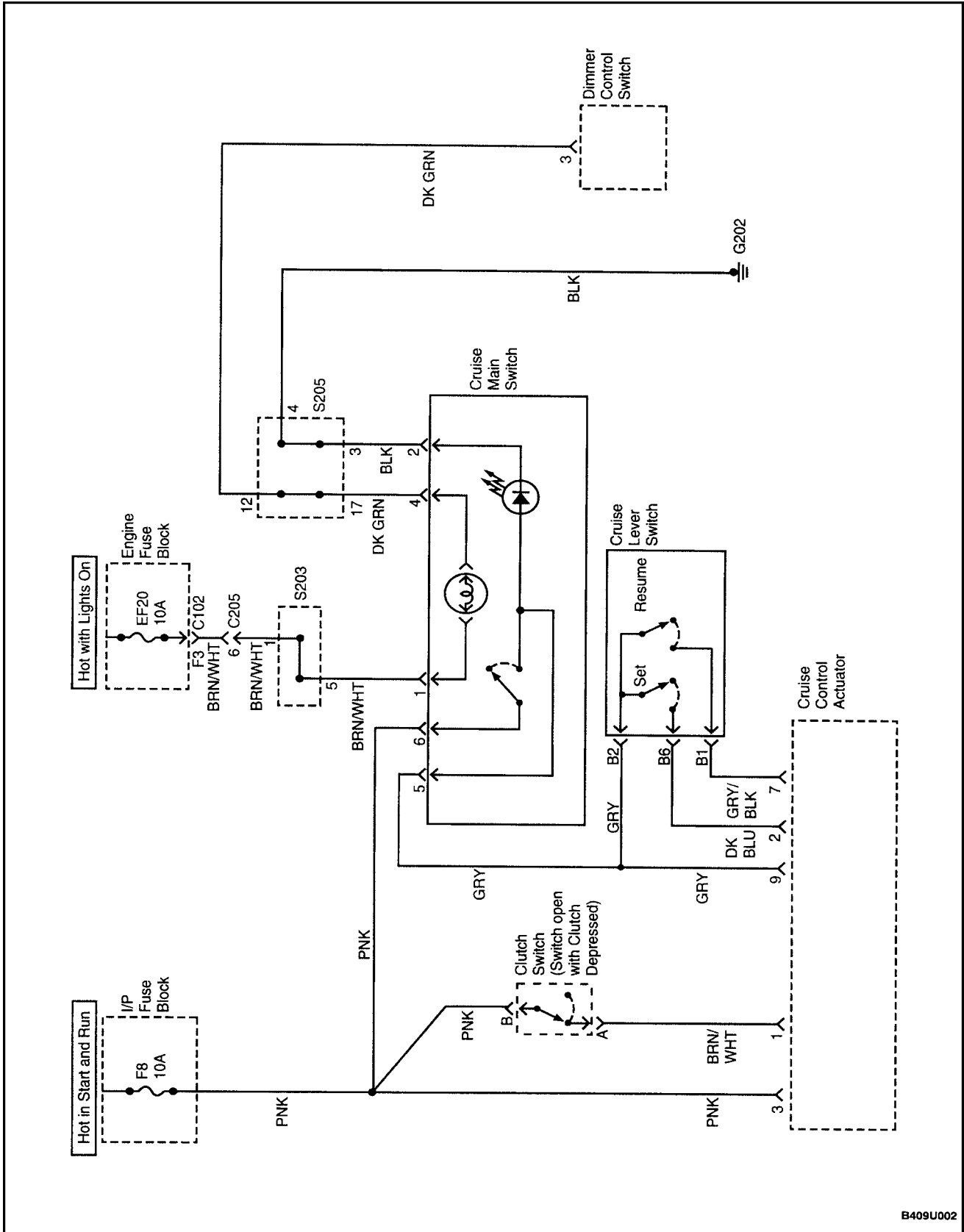

DIAGNOSIS

CRUISE CONTROL DIAGNOSIS

Test Description

The number(s) below refer to step(s) on the diagnostic table.

5. This test is performed because the electromagnetic clutch in the cruise control actuator is grounded through the brake lamps.

Cruise Control Does Not Operate

Step	Action	Value(s)	Yes	No
1	Visually inspect the cruise control system and verify the following conditions: <ul style="list-style-type: none"> • The electrical connector is correctly attached to the cruise control actuator. • The actuator and the bracket are not loose. • The cable is not bent or kinked. • The cable adjuster is correctly attached to its bracket. • The cable and bushing are correctly attached to the accelerator assembly. • The cable is properly adjusted. Are all of the above conditions verified?		Go to <i>Step 3</i>	Go to <i>Step 2</i>
2	Make repairs to the components of the cruise control system that were observed to be faulty in Step 1. Is the repair complete?		System OK	
3	1. Connect a scan tool to the data link connector (DLC). 2. Check for engine control diagnostic trouble codes (DTCs). Is a vehicle speed sensor (VSS) DTC or DTC722 or DTC723 present?		Go to <i>Step 5</i>	Go to <i>Step 4</i>
4	Diagnose and repair the cause of the DTCs. Is the cruise control still inoperative?		Go to <i>Step 5</i>	System OK
5	Observe the brake lamps when the brakes are applied. Do the brake lamps turn on when the brakes are applied and turn off when the brakes are not applied?		Go to <i>Step 7</i>	Go to <i>Step 6</i>
6	Repair the brake lamp system. Does the cruise control operate after the brake lamp system has been repaired?		System OK	Go to <i>Step 7</i>
7	Check fuses F5 and F8. Is a fuse blown?		Go to <i>Step 9</i>	Go to <i>Step 8</i>
8	1. Check for a short circuit and repair it, if necessary. 2. Replace any blown fuses. Is the repair complete?		System OK	
9	1. Turn the ignition ON. 2. Check the voltage at fuses F5 and F8. Is the specified voltage available at fuses F5 and F8?	11–14 v	Go to <i>Step 11</i>	Go to <i>Step 10</i>
10	Repair the power supply to the fuse(s). Is the repair complete?		System OK	

Step	Action	Value(s)	Yes	No
11	<ol style="list-style-type: none"> 1. Disconnect the electrical connector from the cruise control actuator. 2. Turn the ignition ON. 3. Check the voltage at terminal H of the actuator connector. <p>Is the voltage equal to the specified value?</p>	11–14 v	Go to <i>Step 13</i>	Go to <i>Step 12</i>
12	<p>Repair the open circuit between fuseF8 and the cruise control actuatorconnector terminal 3.</p> <p>Is the repair complete?</p>		System OK	
13	<p>With the electrical connectorstill removed fromthe cruise control actuator, use an ohmmeter tomeasure the resistance between connector terminal 6 and ground.</p> <p>Does the ohmmeter indicate the specified value?</p>	$\approx 0 \Omega$	Go to <i>Step 15</i>	Go to <i>Step 14</i>
14	<p>Repair the open circuit between ground and terminal 6 of the actuatorconnector.</p> <p>Is the repair complete?</p>		System OK	
15	<p>With the electrical connectorstill disconnected from the cruise control actuator, use an ohmmeter to measure the resistance between connector terminal 8 and ground.</p> <p>Does the ohmmeter indicate the specified value?</p>	$\approx 0 \Omega$	Go to <i>Step 17</i>	Go to <i>Step 16</i>
16	<p>Repair the open circuit between the actuator connector terminal 8 and the instrument splice pack S202.</p> <p>Is the repair complete?</p>		System OK	
17	<ol style="list-style-type: none"> 1. Turn the ignition ON. 2. With the electrical connector still disconnected from the cruise control actuator, use a voltmeter to check the voltage at terminal 4 of the connector. <p>Is the voltage equal to the specified value?</p>	11–14 v	Go to <i>Step 19</i>	Go to <i>Step 18</i>
18	<p>Repair the open circuit between fuseF5 and terminal 4 of the cruise control actuatorconnector.</p> <p>Is the repair complete?</p>		System OK	
19	<ol style="list-style-type: none"> 1. Turn the ignition ON. 2. With the electrical connector still disconnected from the cruise control actuator, use a voltmeter to check the voltage at terminal 1 of the connector. <p>Is the voltage equal to the specified value?</p>	11–14 v	Go to <i>Step 21</i>	Go to <i>Step 20</i>
20	<p>Repair the open circuit between fuseF8 and terminal 1 of the cruise control actuator.</p> <p>Is the repair complete?</p>		System OK	
21	<ol style="list-style-type: none"> 1. Turn the ignition ON. 2. Make sure that the cruise main switch is OFF. 3. With the electrical connector still disconnected from the cruise control actuator, use a voltmeter to check the voltage at terminal 9 of the actuator connector. <p>Is the voltage equal to the specified value?</p>	$\approx 0 v$	Go to <i>Step 23</i>	Go to <i>Step 22</i>

9U – 8 CRUISE CONRTOL SYSTEM

Step	Action	Value(s)	Yes	No
22	Repair the short to voltage between the cruisemain switch and the cruise control actuatorconnector terminal 9. Is the repair complete?		System OK	
23	1. Turn the ignition ON. 2. Make sure that the cruise main switch is ON. 3. With the electrical connector still disconnected from the cruise control actuator, use a voltmeter to check the voltage at terminal 9 of the connector. Is the voltage equal to the specified value?	11–14 v	Go to <i>Step 29</i>	Go to <i>Step 24</i>
24	1. Remove the cruise control main switch for testing, but leave the electrical connector attached. 2. Turn the ignition ON. 3. Check the voltage at the PNK wire at the cruise main switch. Is the voltage equal to the specified value?	11–14 v	Go to <i>Step 26</i>	Go to <i>Step 25</i>
25	Repair the open circuit in thePNK wire between fuse F8 and the cruise controlmain switch. Is the repair complete?		System OK	
26	1. With the cruise control main switch removed for testing, turn the ignition ON. 2. Turn the cruise control main switch ON. 3. Check the voltage at the GRY wire at the cruise main switch. Is the voltage equal to the specified value?	11–14 v	Go to <i>Step 27</i>	Go to <i>Step 25</i>
27	Replace the cruise control main switch. Is the repair complete?		System OK	
28	Repair the open circuit between the cruise control main switch connector terminal 5 and the cruise control actuatorconnector terminal 9. Is the repair complete?		System OK	
29	1. Turn the ignition ON. 2. Turn the cruise control main switch ON. 3. With the electrical connector still disconnected from the cruise control actuator, check the voltage at terminals 7 and 2 of the connector. Is the voltage equal to the specified value?	≈ 0 v	Go to <i>Step 33</i>	Go to <i>Step 30</i>
30	1. Disconnect the 6–pin connector at the cruise control lever switch. 2. Turn the ignition ON. 3. Turn the cruise control main switch ON. 4. With the electrical connector still disconnected from the cruise control actuator, check the voltage at terminals 7 and 2 of the cruise control actuator. Is the voltage equal to the specified value?	0 v	Go to <i>Step 31</i>	Go to <i>Step 32</i>
31	Replace the cruise control lever switch. Is the repair complete?		System OK	
32	Repair the short to voltage between the cruise control lever switch and the cruise control actuator. Is the repair complete?		System OK	

Step	Action	Value(s)	Yes	No
33	<ol style="list-style-type: none"> 1. Turn the ignition ON. 2. Turn the cruise control main switch ON. 3. Select SET on the cruise control lever switch. 4. While holding the lever switch in the SET position, check the voltage at terminal 2 of the connector for the cruise control actuator. <p>Does the voltmeter indicate the specified value?</p>	11–14 v	Go to <i>Step 39</i>	Go to <i>Step 34</i>
34	<ol style="list-style-type: none"> 1. Disconnect the 6–pin connector from the lever switch. 2. Turn the ignition ON. 3. Turn the cruise control main switch ON. 4. Check the voltage at terminal 3 of the wiring harness side of the 6–pin lever switch connector. <p>Is the voltage equal to the specified value?</p>	11–14 v	Go to <i>Step 36</i>	Go to <i>Step 35</i>
35	<p>Repair the open circuit between the cruise control main switch and the cruise control lever switch.</p> <p>Is the repair complete?</p>		System OK	
36	<ol style="list-style-type: none"> 1. Disconnect the 6–pin connector from the lever switch. 2. Connect an ohmmeter between terminals 3 and 8 at the switch side of the 6–pin connector. 3. Observe the ohmmeter when moving the lever switch to the SET position. <p>Does the ohmmeter indicate the specified value?</p>	$\approx 0 \Omega$	Go to <i>Step 38</i>	Go to <i>Step 37</i>
37	<p>Replace the lever switch.</p> <p>Is the repair complete?</p>		System OK	
38	<p>Repair the open circuit between the leverswitch connector terminal B6 and the cruise control actuator connector terminal 2.</p> <p>Is the repair complete?</p>		System OK	
39	<ol style="list-style-type: none"> 1. Turn the ignition ON. 2. Turn the cruise control main switch ON. 3. Select RESUME on the cruise control lever switch. 4. While holding the lever switch in the RESUME position, check the voltage at terminal 7 of the connector for the cruise control actuator. <p>Does the voltmeter indicate the specified value?</p>	11–14 v	Go to <i>Step 42</i>	Go to <i>Step 40</i>
40	<p>Use the ohmmeter to check for an open circuit between terminal B1 of the wiring harness at the lever switch and terminal 7 of the actuator connector.</p> <p>Does the ohmmeter indicate the specified value?</p>	$\approx 0 \Omega$	Go to <i>Step 37</i>	Go to <i>Step 41</i>
41	<p>Repair the open circuit between terminal B1 of the leverswitch connector and terminal 7 of the cruise control actuator connector.</p> <p>Is the repair complete?</p>		System OK	

9U – 10 CRUISE CONRTOL SYSTEM

Step	Action	Value(s)	Yes	No
42	<ol style="list-style-type: none"> 1. Turn the ignition OFF. 2. If the vehicle has a manual transaxle, disconnect the VSS electrical connector. 3. If the vehicle has an automatic transaxle, disconnect the electrical connector from the transaxle output shaft sensor. <ul style="list-style-type: none"> • If the vehicle has a manual transaxle, use an ohmmeter to check continuity between the DK GRN/WHT wire at the VSS and terminal 10 of the cruise control actuator connector. • If the vehicle has an automatic transaxle, check the continuity of the following wires: <ul style="list-style-type: none"> – The YEL wire between cruise control actuator connector terminal 10 and VSS connector terminal A. – The PPL wire between cruise control actuator connector terminal 5 and VSS connector terminal B. <p>Does the ohmmeter indicate the specified value when checking the wire(s) between the cruise control module and the VSS, for vehicles with a manual transaxle, or the output shaft sensor, for vehicles with an automatic transaxle?</p>	≈ 0 Ω	Go to Step 44	Go to Step 43
43	<p>Repair the open circuit between the cruise control actuator connector terminal 10 and the VSS, for vehicles with a manual transaxle, or the output shaft sensor for vehicles with an automatic transaxle. Is the repair complete?</p>		System OK	
44	<p>Replace the cruise control actuator. Is the repair complete?</p>		System OK	

MAINTENANCE AND REPAIR

ON-VEHICLE SERVICE

CRUISE CONTROL ACTUATOR

Removal Procedure

1. Carefully pull the knee bolster trim panel until it is loose from its retaining clips.
2. Remove the knee bolster. Refer to *Section 9G, Interior Trim*.
3. Remove the actuator bracket with the actuator still attached.
4. Press the tabs on the cable adjuster, and remove the cable and the adjuster from the adjuster bracket.

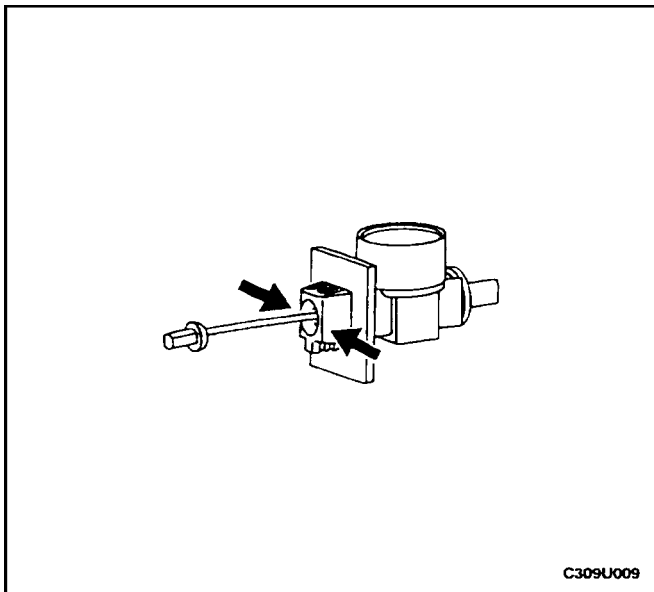
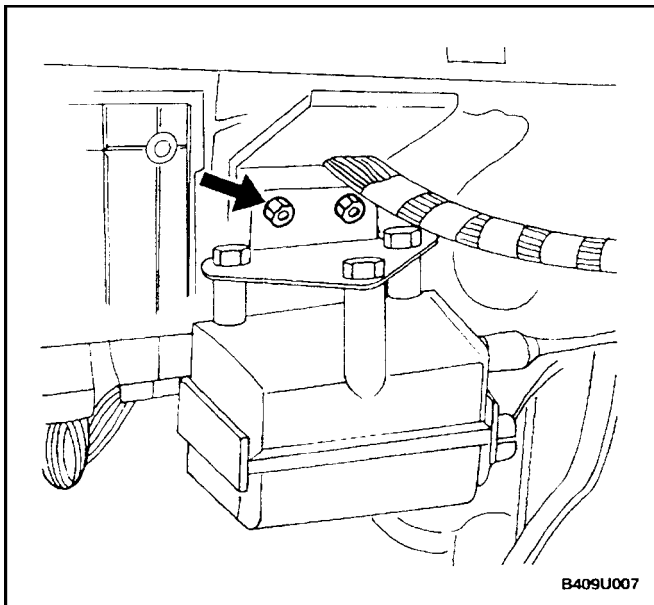
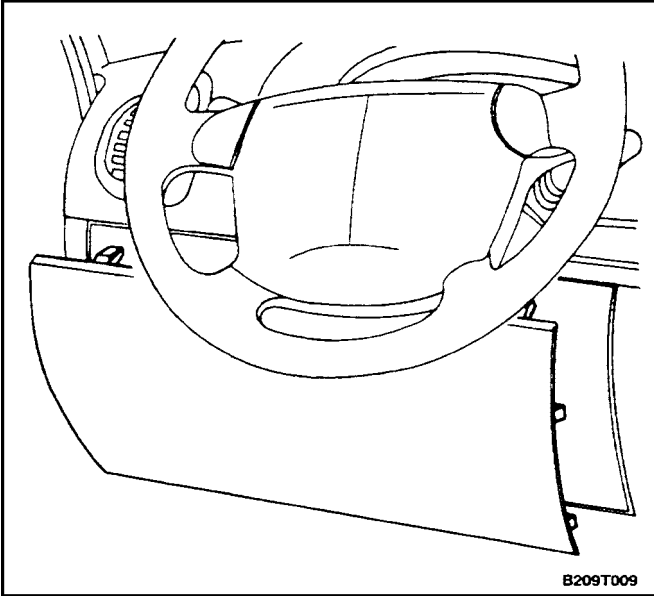

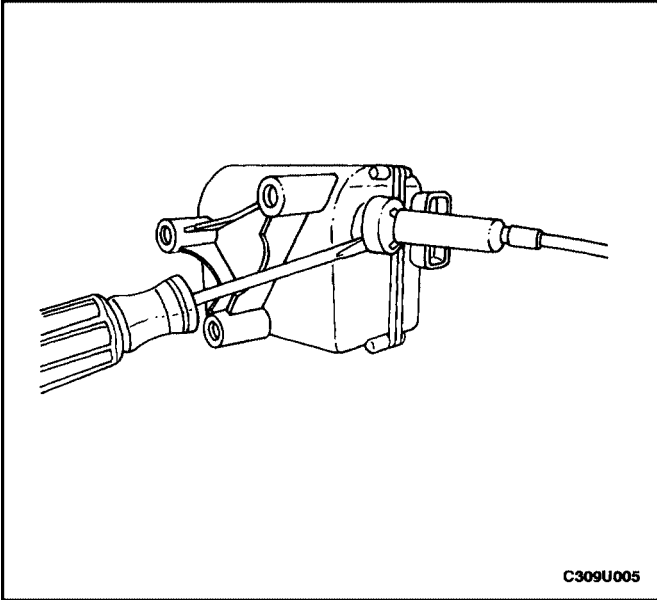

5. Tilt the cable housing to expose one of the slots in the actuator, and insert the tip of a flathead screwdriver into one of the slots.

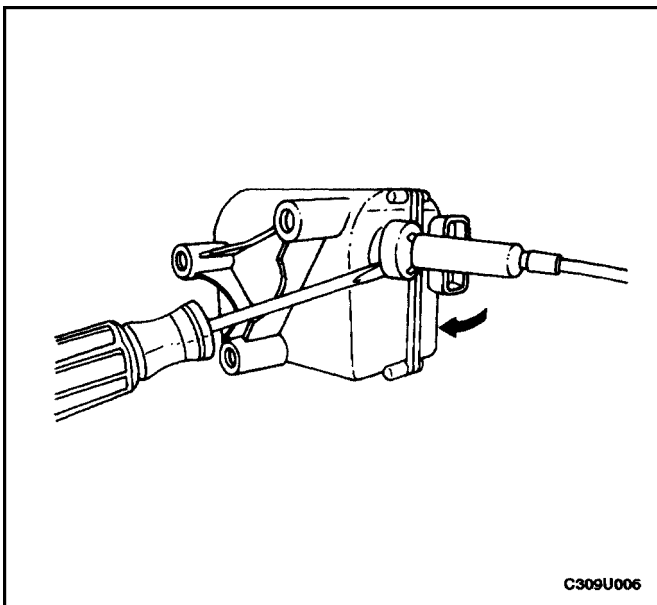

6. Tilt the cable housing toward the screwdriver to release the cable housing retainers.

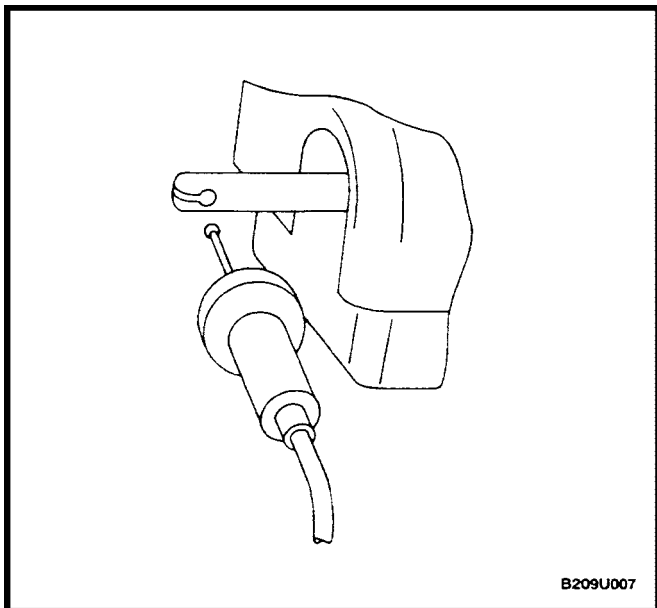

7. Remove the cable ball from the actuator rod.

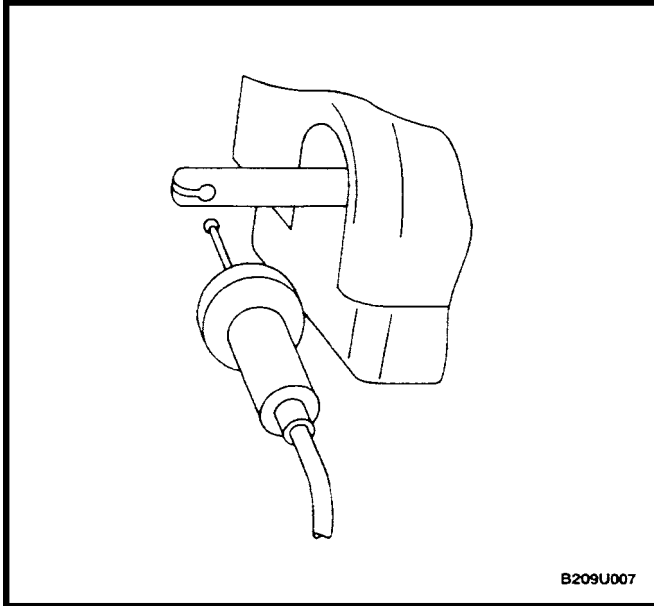

Installation Procedure

1. Insert the cable ball into the actuator rod.

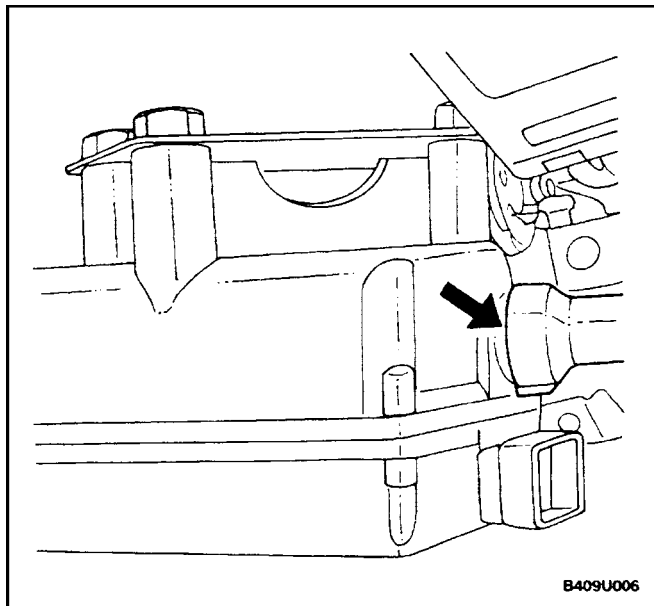

2. Align the cable housing and push the cable housing onto the actuator until it is locked in place by the retainers.

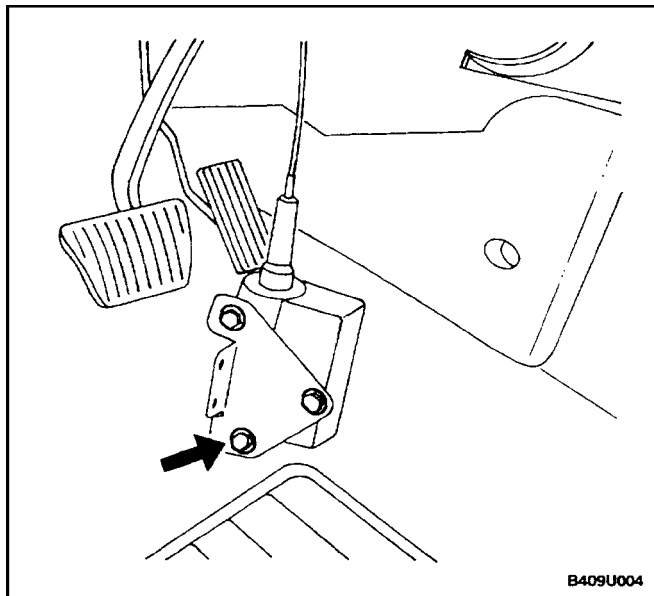

3. If a new actuator is being installed, attach it to the mounting bracket.

Tighten

Tighten the actuator bolts to 4 N•m (35 lb-in).

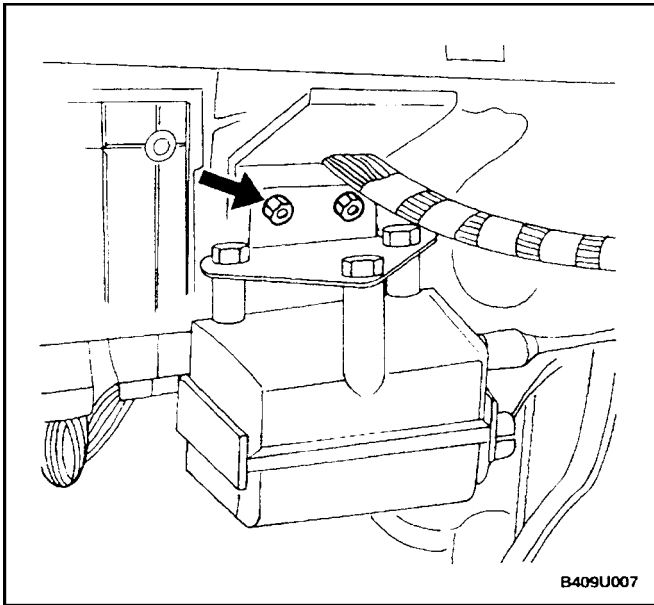

4. Install the mounting bracket.

Tighten

Tighten the actuator bracket nuts to 18 N•m (13 lb–ft).

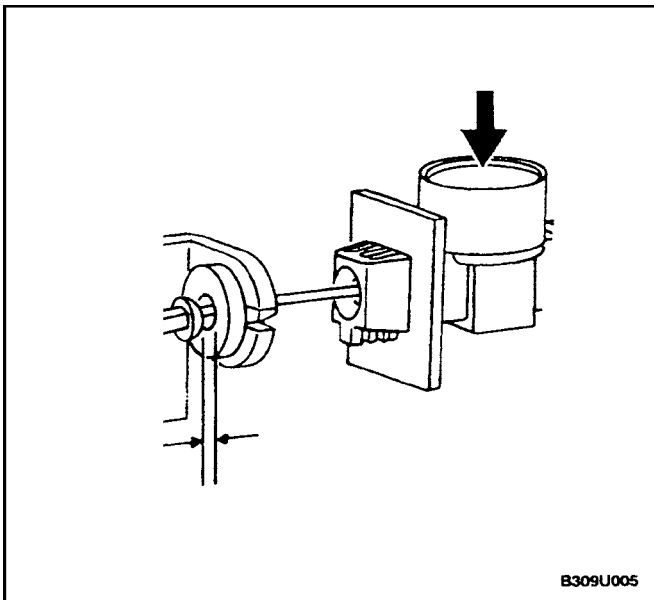

5. If the adjuster spring is not fully compressed, press the cable release button and slide the cable into the adjuster until the spring is fully compressed.

Notice : When the adjuster button is pressed, do not allow the adjuster spring to expand to a length of more than 2 cm (3/4 inch) or the adjuster rack will come out of the adjuster, and will have to be re–inserted. To keep the adjuster in one piece during adjustment, hold the cable when the adjuster button is pressed.

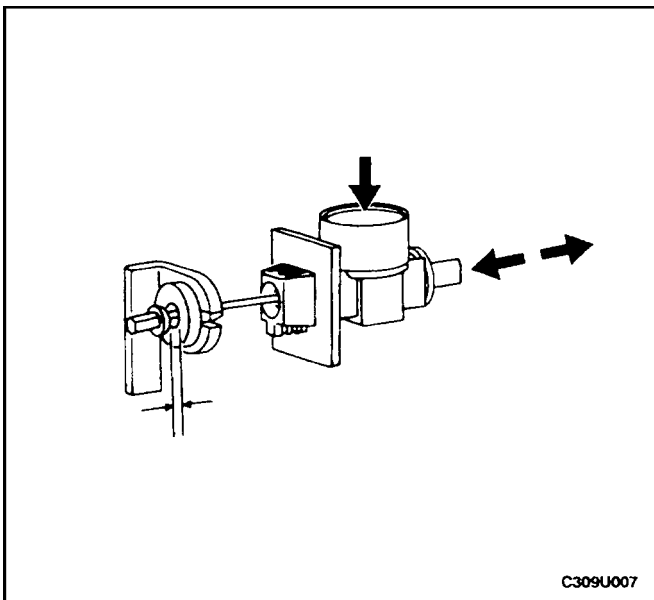

6. Insert the cable adjuster into the adjuster bracket.
7. Press the cable release button and adjust the cable to achieve a gap of 0.5 mm (0.02 inches) between the bushing and the nipple of the cable ball.
8. Install the knee bolster. Refer to *Section 9G, Interior Trim*.
9. Install the knee bolster trim panel.

ACTUATOR CONTROL CABLE

Removal Procedure

1. Press the release button on the cable adjuster, and push the cable toward the adjuster until the adjuster spring is compressed.

Notice : When the adjuster button is pressed, do not allow the adjuster spring to expand to a length of more than 2 cm (3/4 inch) or the adjuster rack will come out of the adjuster, and will have to be re-inserted. To keep the adjuster in one piece during adjustment, hold the cable when the adjuster button is pressed.

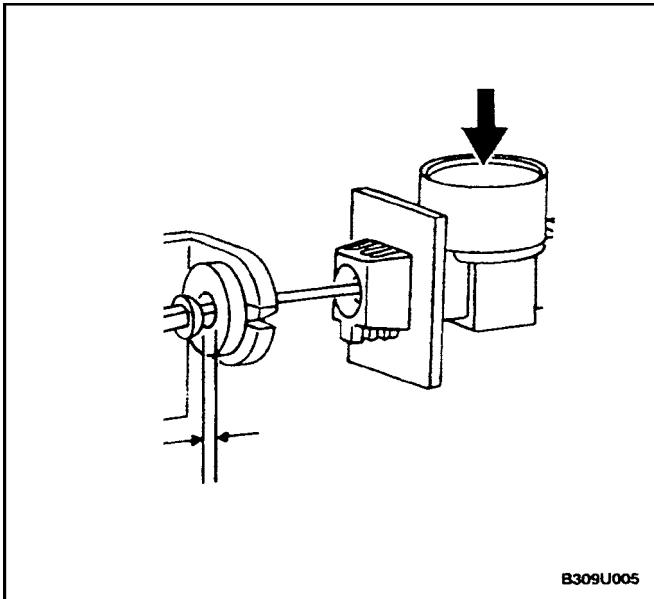

2. Press the retaining tabs of the cable adjuster, and remove the adjuster from the mounting bracket.

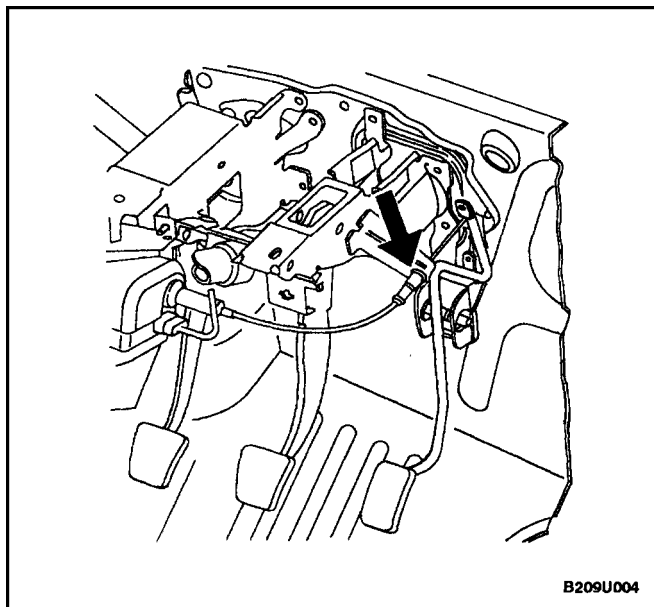

3. Tilt the cable housing and insert a flathead screwdriver into one of the slots in the actuator.
4. Tilt the cable housing toward the screwdriver, so that the cable housing retainers will release.

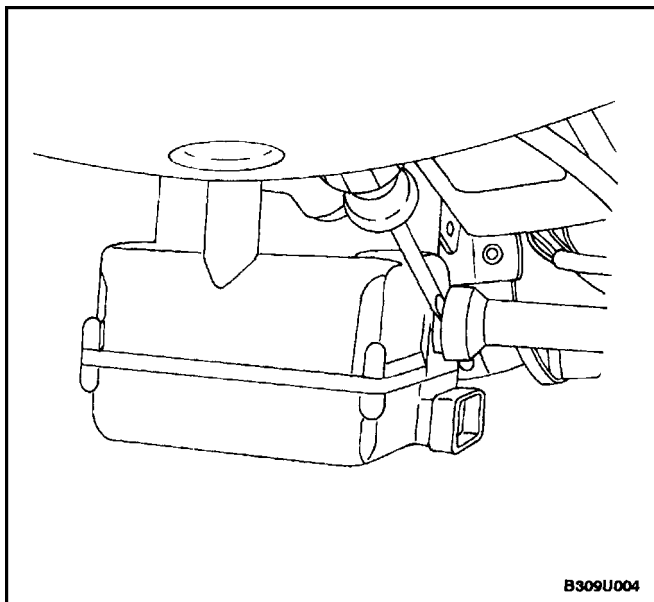

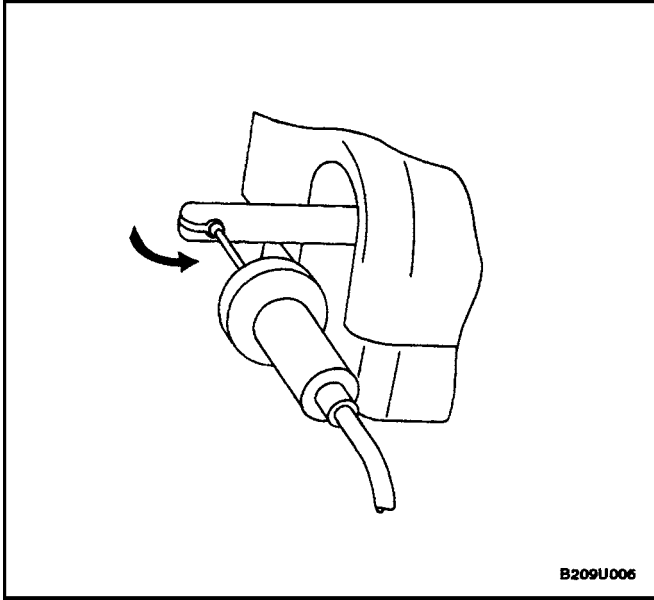

5. Slide the sleeve and the cable out of the actuator and rotate the cable so it can be removed from the slot in the actuator rod.

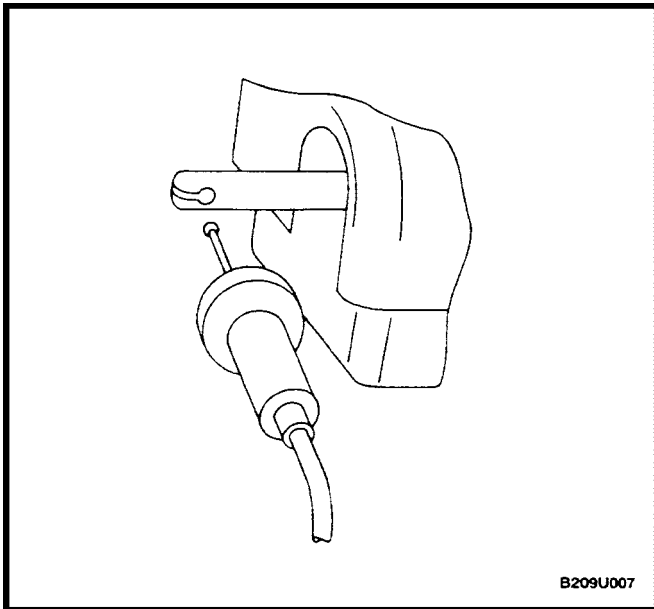

6. Remove the cable ball from the actuator rod.

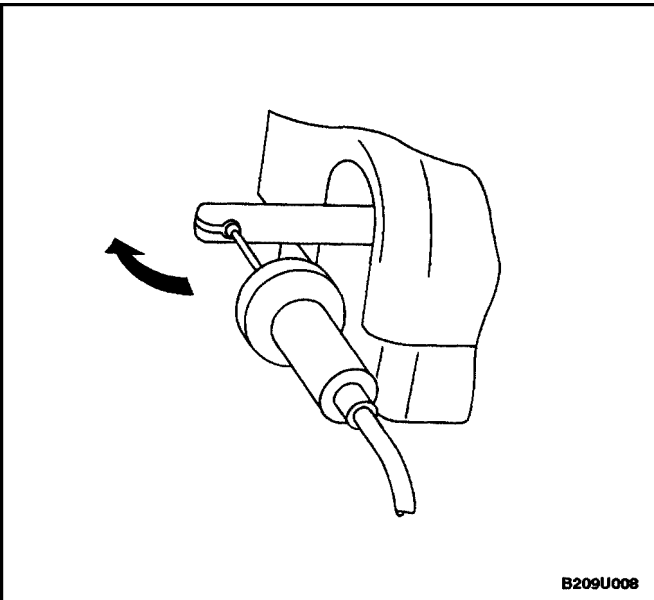

Installation Procedure

1. Insert the ball nipple of the cable assembly into the slot in the actuator rod, and then rotate the cable 90 degrees.

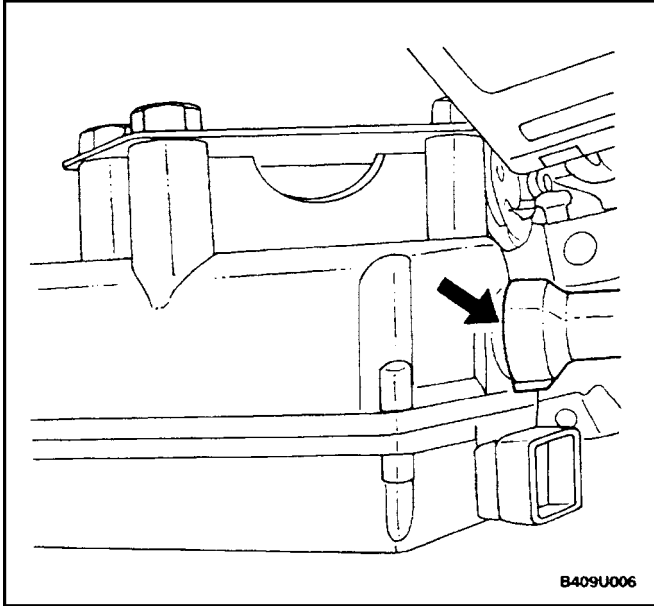

2. Align the cable housing and push the cable housing onto the actuator until it is locked in place by the retainers.

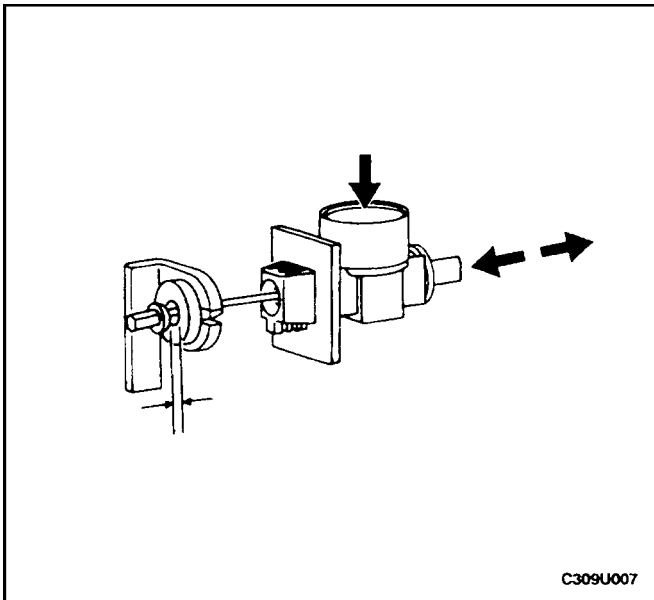

3. Insert the cable adjuster into the bracket of the pedal mount assembly.
4. If the adjuster spring is not fully compressed, press the cable release button and slide the cable into the adjuster until the spring is fully compressed.
5. Install the cable bushing into the pedal assembly.
6. Press the cable release button and adjust the cable to achieve a gap of 0.5 mm (0.02 inches) between the bushing and the nipple of the ball.

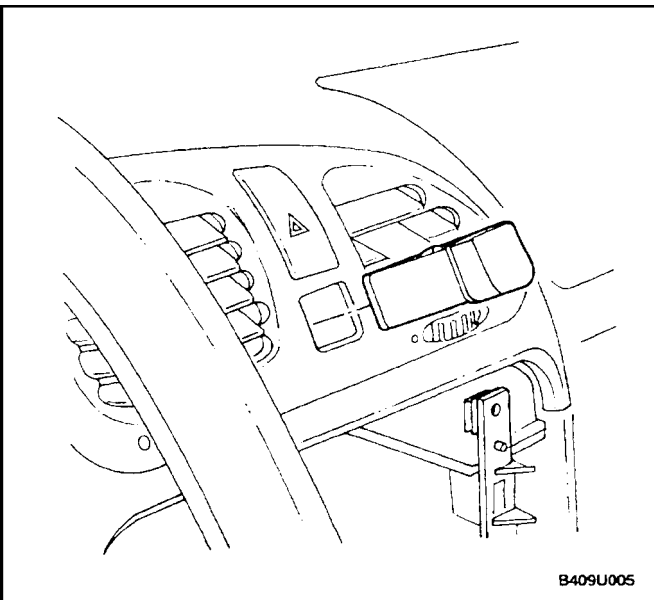

MAIN SWITCH

Removal Procedure

1. Remove the radio, taking care not to scratch the instrument panel or trim with the corners of the radio case. Refer to *Section 9F, Audio Systems*.
2. Reach through the radio opening in the instrument panel and wiggle the cruise control main switch to loosen it.
3. Push the cruise control main switch out of the instrument panel.
4. Disconnect the electrical connector from the cruise control main switch.

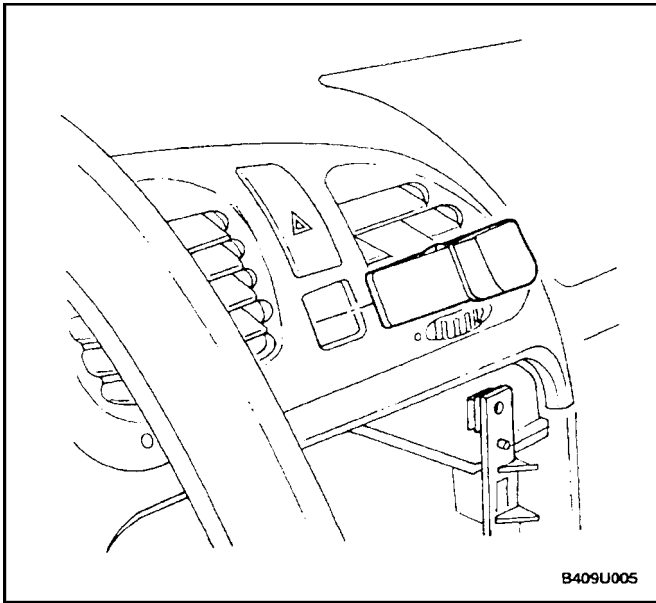

Installation

1. Connect the electrical connector to the cruise control main switch.
2. Push the cruise control main switch into the instrument panel until it is locked in place by its retainers.
3. Reinstall the radio, taking care not to scratch the instrument panel or trim when installing the radio case. Refer to *Section 9F, Audio Systems*.

GENERAL DESCRIPTION AND SYSTEM OPERATION

CRUISE CONTROL SYSTEM OPERATION

The cruise control system automatically maintains a vehicle speed set by the driver. When the cruise control system is activated, speed is maintained or increased by means of an electronically controlled cable attached to the accelerator assembly. If the vehicle must be slowed to maintain the speed set by the driver, the cruise control system allows the throttle return spring to close the throttle.

If driving conditions require sudden acceleration after the cruise control has been set, speed can be increased in the normal manner by manually pressing the accelerator. The cruise control is disengaged if the brakes (or the clutch, with a manual transaxle) are applied.

The minimum speed for setting the cruise control is 38.6 km/h (24 mph). When cruise control is operating, the CRUISE indicator lamp is turned ON in the instrument cluster.

The cruise control system is capable of monitoring internal software and hardware faults as well as external faults in the connectors and the wire harness. If a fault is detected, cruise control is stopped immediately, and the program logic and hardware logic both prevent the cruise control from opening the throttle.

The cruise control will function in temperatures ranging from -40°C (-40°F) to 85°C (185°F). Maximum temperature could cause the regulation properties to be out of tolerance, but the safety shutdown is still operational under maximum temperature conditions. If high temperature interferes with the cruise control operation, the actuator electromagnetic clutch will open, and the throttle return spring will close the throttle unless the accelerator pedal is pressed.

CRUISE CONTROL ACTUATOR

The cruise control actuator is a single-component system. The electronic controls are combined in one housing with the mechanical components. The actuator is mounted in the passenger compartment.

The mechanical components of the cruise control actuator are listed below:

- Permanent field DC motor.
- Single stage belt transfer gearing.
- Spindle drive.
- Electromagnetic clutch.
- Clutch plate with cable attachment.
- End switches.
- Plastic housing with noise reduction cover.
- Damping unit for clutch plate slap.

The electronics of the cruise control system include the following items:

- A microprocessor which controls speed regulation and monitors input signals.
- A clutch activation circuit which energizes the clutch magnet in order to couple the DC motor to the control cable.
- A driver circuit which activates the DC motor in a clockwise or counterclockwise direction.
- A control unit for lamp activation.

The parts of the cruise control actuator are not serviceable. The entire actuator must be replaced if there is an electronic or mechanical defect in one of the systems.

MAIN SWITCH

The cruise control main switch is on the center of the instrument panel.

Cruise control can only be set with the lever switch when the main switch is ON.

The main switch has an indicator which turns ON when the main switch is pressed. If the switch is pressed again, the indicator and the switch turn OFF.

The main switch also is connected to the instrument illumination system, so the dimmer switch controls switch illumination when the headlamps or parking lamps are ON.

LEVER SWITCH

After the main switch is turned ON and the neutral position of the lever switch is detected by the cruise control actuator, the following operations can be performed by using the cruise control lever switch:

Set – If the cruise control is ON and the minimum speed is 38.6 km/h (24 mph) but not more than 155 km/h (96 mph), the target speed can be set by selecting the SET function for 10 to 300 milliseconds. If SET is selected for more than 300 milliseconds, the cruise will be activated in the COAST function. If the accelerator is pressed by the driver after the cruise control has been set, the previous target speed will be maintained when the accelerator is released. If the accelerator is pressed by the driver until the actual speed is more than 35 km/h (22 mph) over the target speed, or until the vehicle exceeds 160 km/h (99 mph), the cruise control will disengage.

Coast – If a target speed has been set and COAST is selected for at least 300 milliseconds, the throttle is allowed to return to idle and the vehicle will coast. When the COAST switch is released, the current speed will be maintained as the new target speed. If the vehicle speed drops

below 32.2 km/h (20 mph) while coasting, the cruise control will be disengaged. If the switch is released between 32.2 km/h (20 mph) and 38.6 km/h (24 mph), the minimum target speed of 38.6 km/h (24 mph) will be used.

Resume – If the cruise control is ON and the system is disengaged by using the brake or the clutch, exceeding the maximum speed, failing to maintain the minimum speed, or exceeding the target speed by more than 35 km/h (22 mph), the last memorized speed can be reset by selecting RESUME, if the time since disengagement is not greater than 5 seconds. The RESUME function is selected by switching to RESUME for 10 to 300 milliseconds. If the actual speed is below the target speed when RESUME is selected, the vehicle will be accelerated at 3.4 km/h per second (2.1 mph/second) until the vehicle is within 10 km/h (6 mph) of the target speed, and then acceleration will be reduced in order to achieve a smooth transition from acceleration to cruising. If the actual speed is above the target speed when RESUME is selected, the throttle will be allowed to return to idle until the target speed is achieved. RESUME can be canceled by selecting SET. In that case, the current speed will be maintained as the new target speed.

Accelerate – If cruise control is ON, and the ACCEL function is selected for more than 300 milliseconds, the vehicle will accelerate. The acceleration is maintained at the rate of 3.4 km/h per second (2.1 mph/second) as long as vehicle performance is sufficient; otherwise full throttle is applied. When the switch is released, the current speed will be stored and used as the new target speed. The ACCEL function cannot be used for acceleration above 155 km/h

(96 mph). If 155 km/h (96 mph) is attained, acceleration will stop and 155 km/h (96 mph) will be set as the new target speed.

Tap-Up – If the cruise control has been set, and RESUME is selected again for more than 10 milliseconds but less than 300 milliseconds, the target speed will be increased by 2 km/h (1.2 mph) each time the RESUME function is selected (or tapped). If the driver has used the accelerator to increase speed more than 8 km/h over the current target speed, a tap-up signal will be interpreted as a normal SET signal. The cruise control will not accept a tap-up target speed above 155 km/h (96 mph). If the actual speed has fallen 16.1 km/h (10 mph) below the target speed, tap-up signals are not accepted.

Tap-Down – If the cruise control is already set and SET is selected for between 10 and 300 milliseconds, the target speed will be decreased by 2 km/h (1.2 mph) each time SET is selected (or tapped). Tap-down signals will not be accepted for a target speed below 38.6 km/h (24 mph). If the vehicle speed has increased to 8 km/h (5 mph) over the target speed, the cruise control system will interpret a tap-down signal as a SET.

If the cruise control is turned OFF with the main switch, all cruise control functions are stopped, the actuator cable is driven toward idle, and the electromagnetic clutch for the cable actuator is opened. The cable actuator clutch is not opened immediately in order to accomplish a smooth transition in vehicle speed. If the cruise control is OFF for more than 5 seconds, the memorized target speed is erased.

SCHEMATIC AND ROUTING DIAGRAMS

HEADLAMPS-ON REMINDER CHIME CIRCUIT

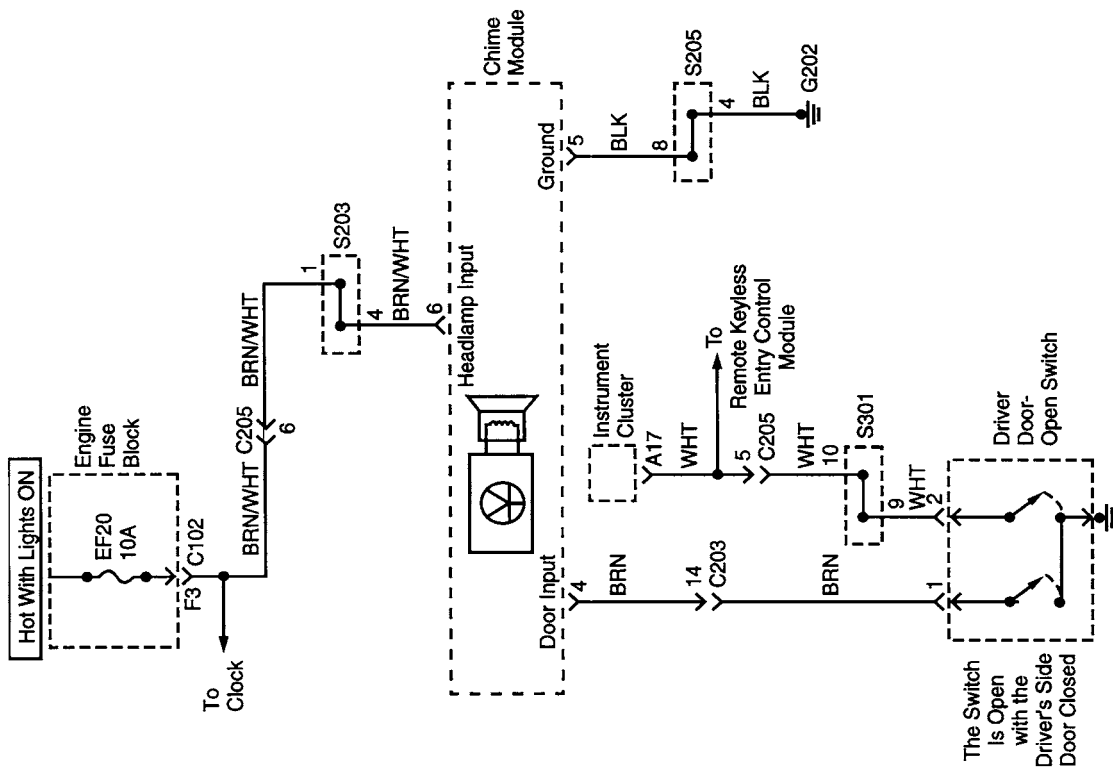

PARKING, TAIL, POSITION AND LICENSE LAMPS CIRCUIT

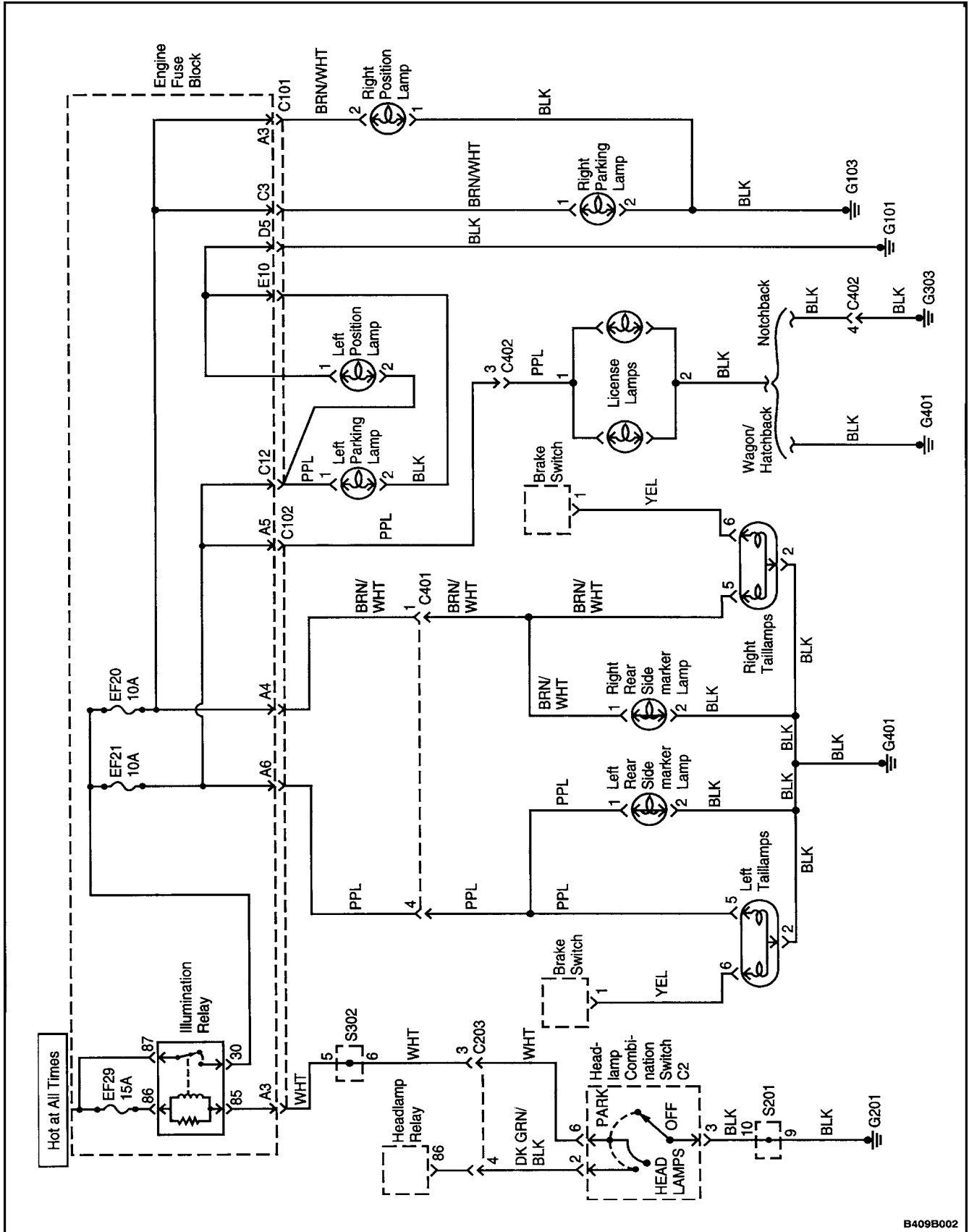

TURN AND HAZARD LAMPS CIRCUIT

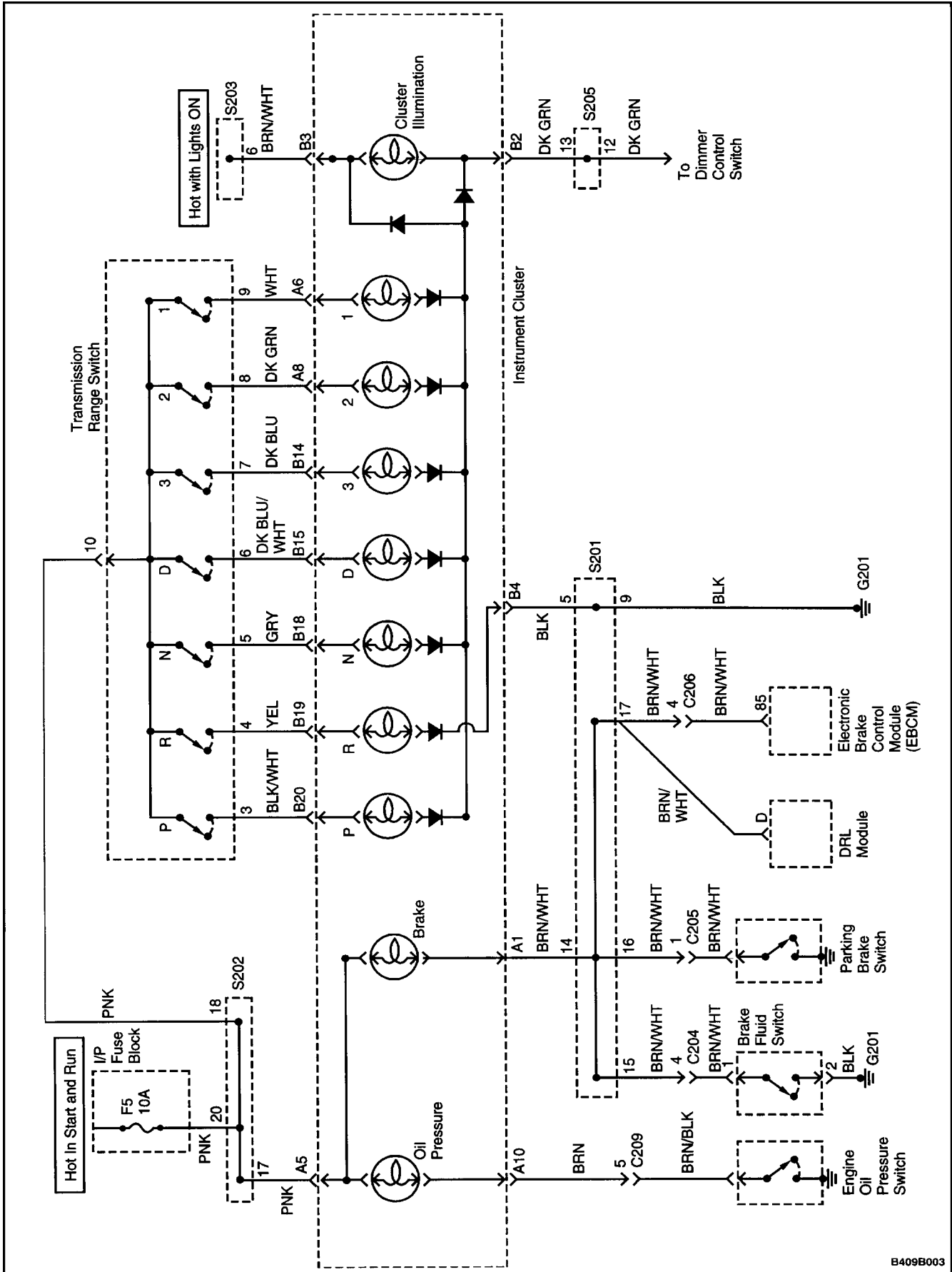

BRAKE AND BACKUP LAMPS CIRCUIT

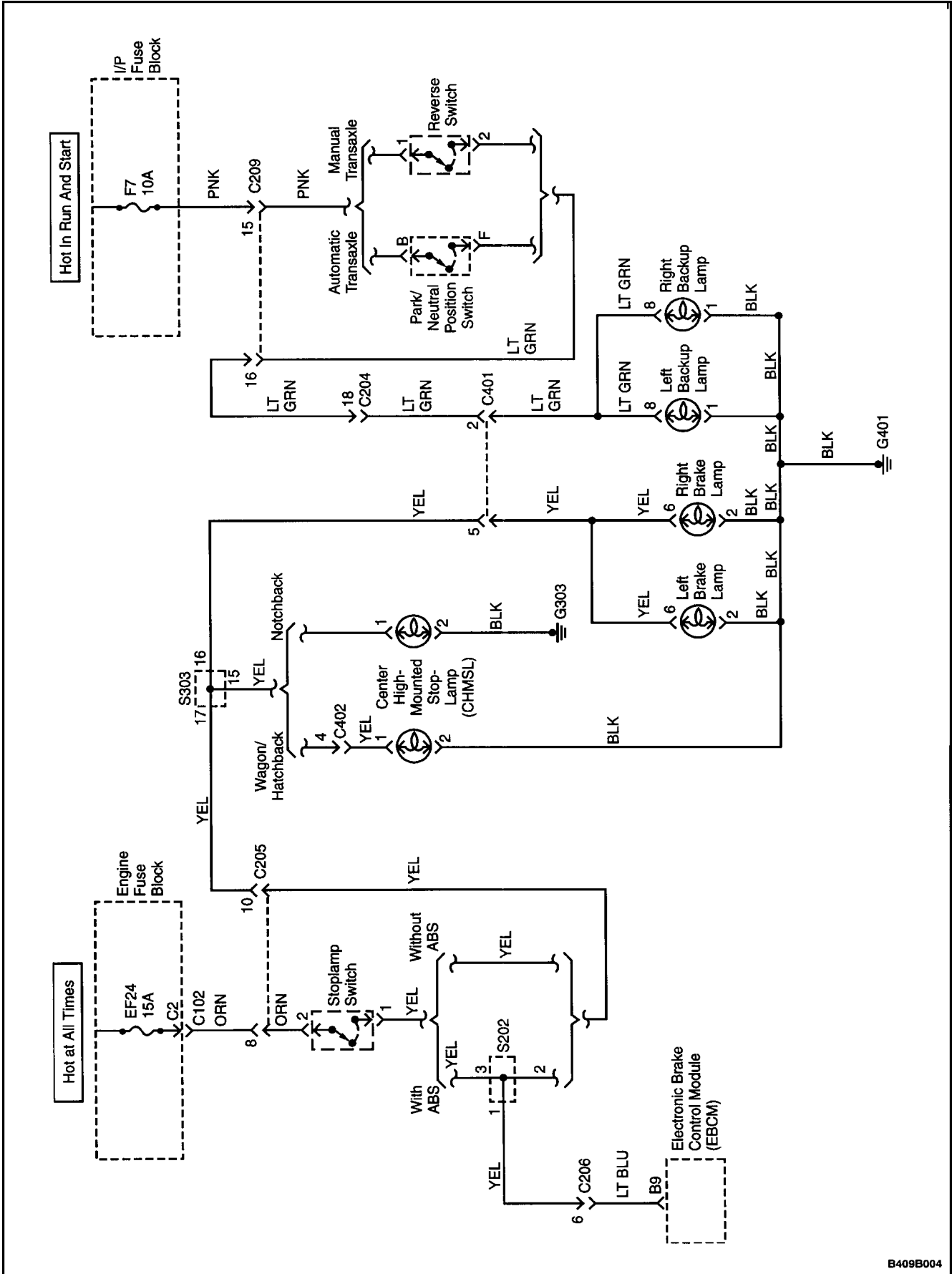

SECTION : 9C

HORNS

CAUTION : *Disconnect the negative battery cable before removing or installing any electrical unit or when a tool or equipment could easily come in contact with exposed electrical terminals. Disconnecting this cable will help prevent personal injury and damage to the vehicle. The ignition must also be in LOCK unless otherwise noted.*

TABLE OF CONTENTS

SPECIFICATIONS	9C-1	ON-VEHICLE SERVICE	9C-3
FASTENER TIGHTENING SPECIFICATIONS .	9C-1	HORNS	9C-3
SCHEMATIC AND ROUTING DIAGRAMS	9C-2	GENERAL DESCRIPTION AND SYSTEM	
HORN WIRING SYSTEM	9C-2	OPERATION	9C-5
MAINTENANCE AND REPAIR	9C-3	HORNS	9C-5

SPECIFICATIONS

FASTENER TIGHTENING SPECIFICATIONS

Application	N•m	Lb-Ft	Lb-In
Horn Bolt	20	15	–

SCHEMATIC AND ROUTING DIAGRAMS

HORN WIRING SYSTEM

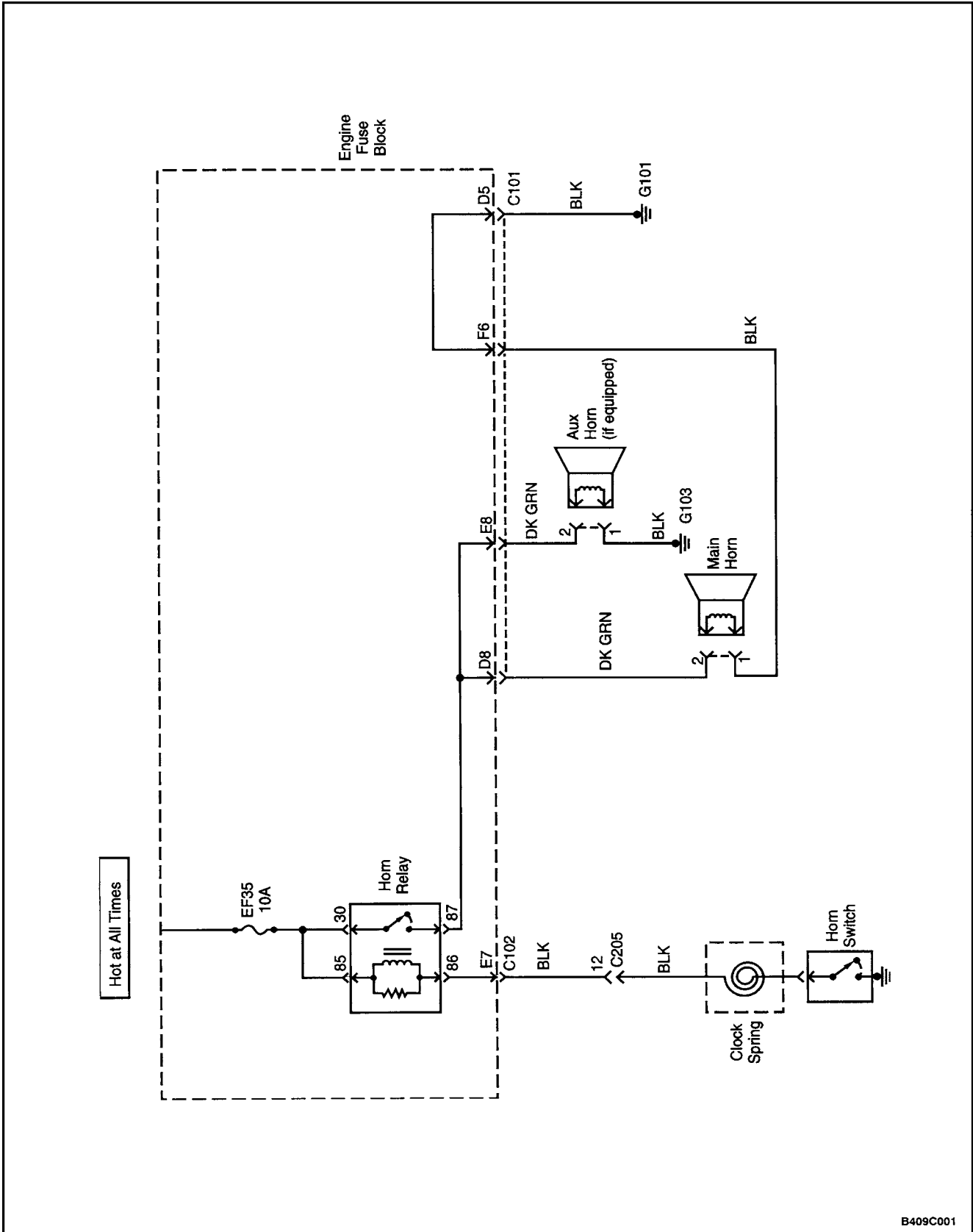

MAINTENANCE AND REPAIR

ON-VEHICLE SERVICE

HORNS

(Left Horn Shown, Right Horn Similar, If Equipped)

Removal Procedure

1. Disconnect the negative battery cable.
2. Disconnect the electrical connector.
3. Remove the bolt and the horn.

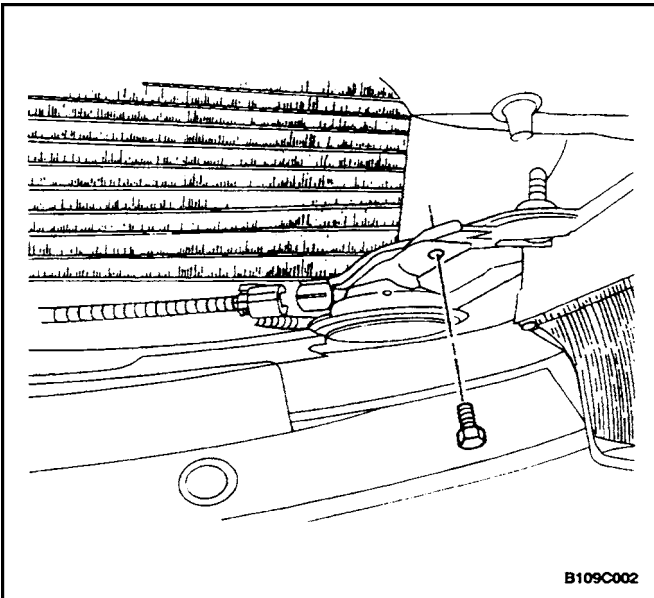
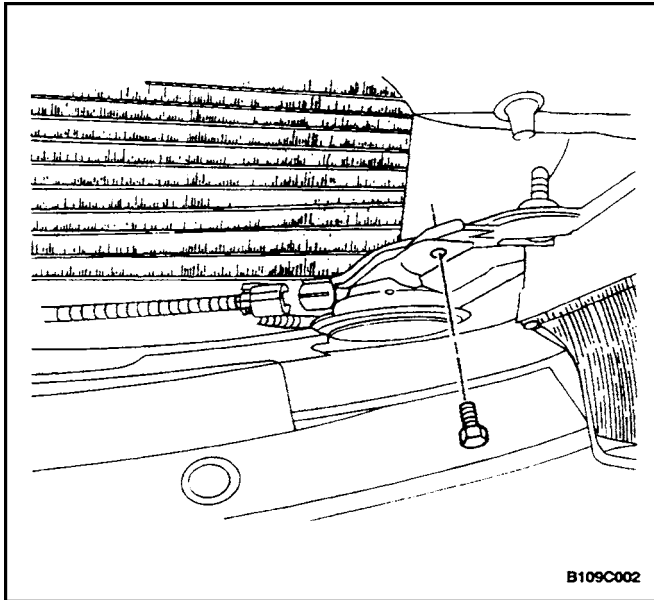
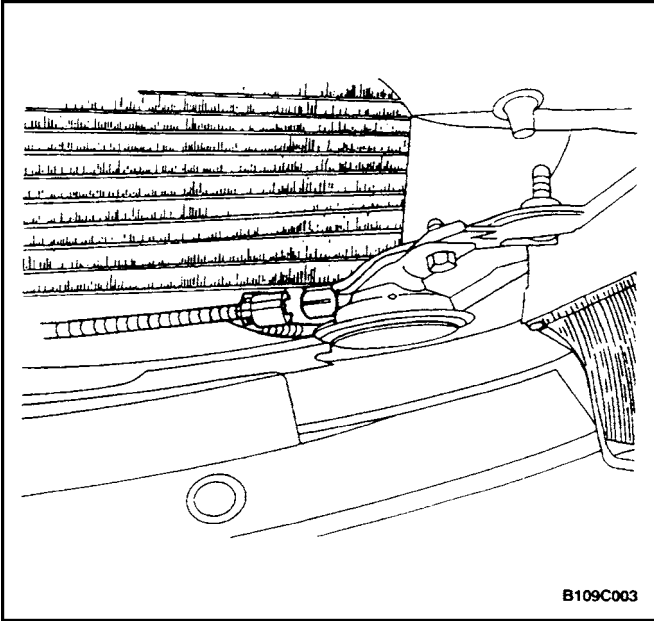

Installation Procedure

Notice : Dissimilar metals in direct contact with each other may corrode rapidly. Make sure to use the correct fasteners to prevent premature corrosion.

1. Install the horn with the bolt.

Tighten

Tighten the horn bolt to 22 N•m (16 lb–ft)

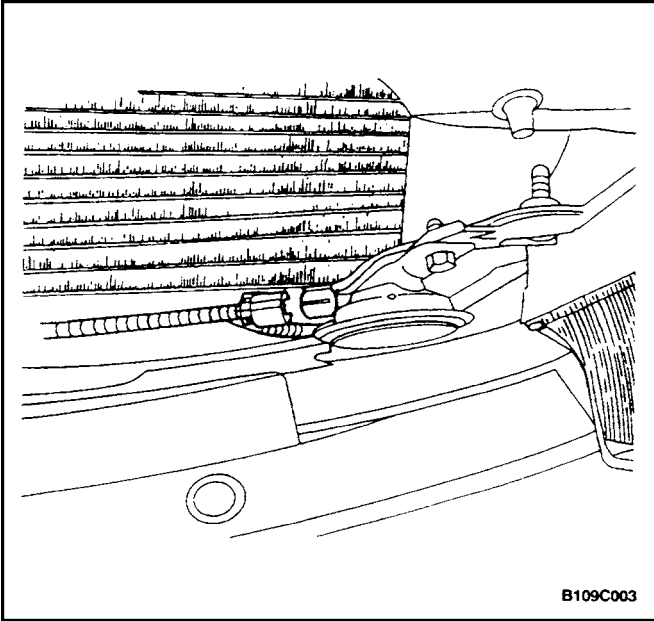

B109C003

2. Connect the electrical connector.
3. Connect the negative battery cable.

GENERAL DESCRIPTION AND SYSTEM OPERATION

HORNS

The horns are located under the hood. They are attached near the radiator at the front of the vehicle. The horns are actuated by pressing the steering wheel pad, which grounds the horns' electrical circuit.

INTERIOR COURTESY LAMP AND LUGGAGE COMPARTMENT LAMP CIRCUIT

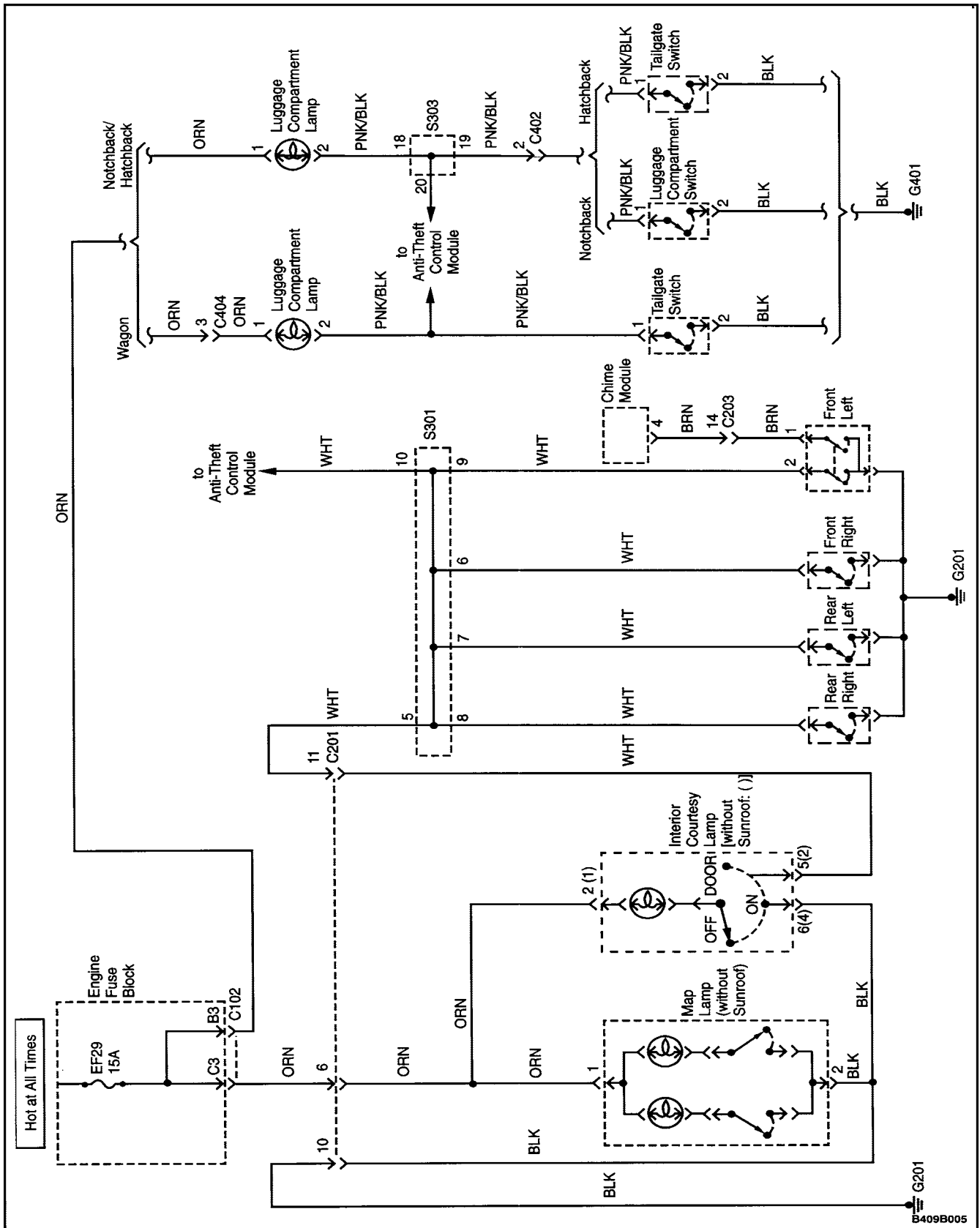

HEADLAMPS CIRCUIT

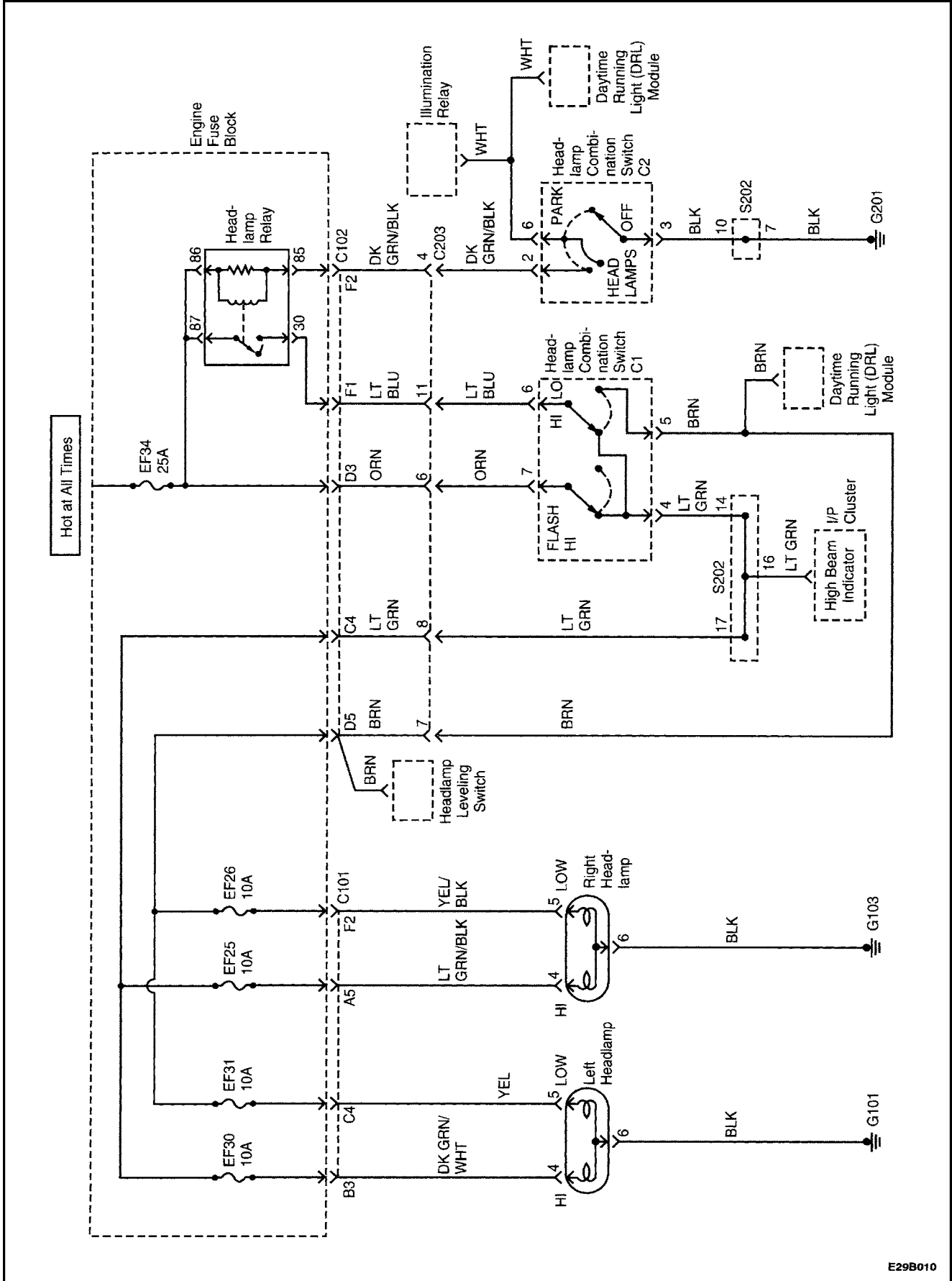

DAYTIME RUNNING LAMPS CIRCUIT

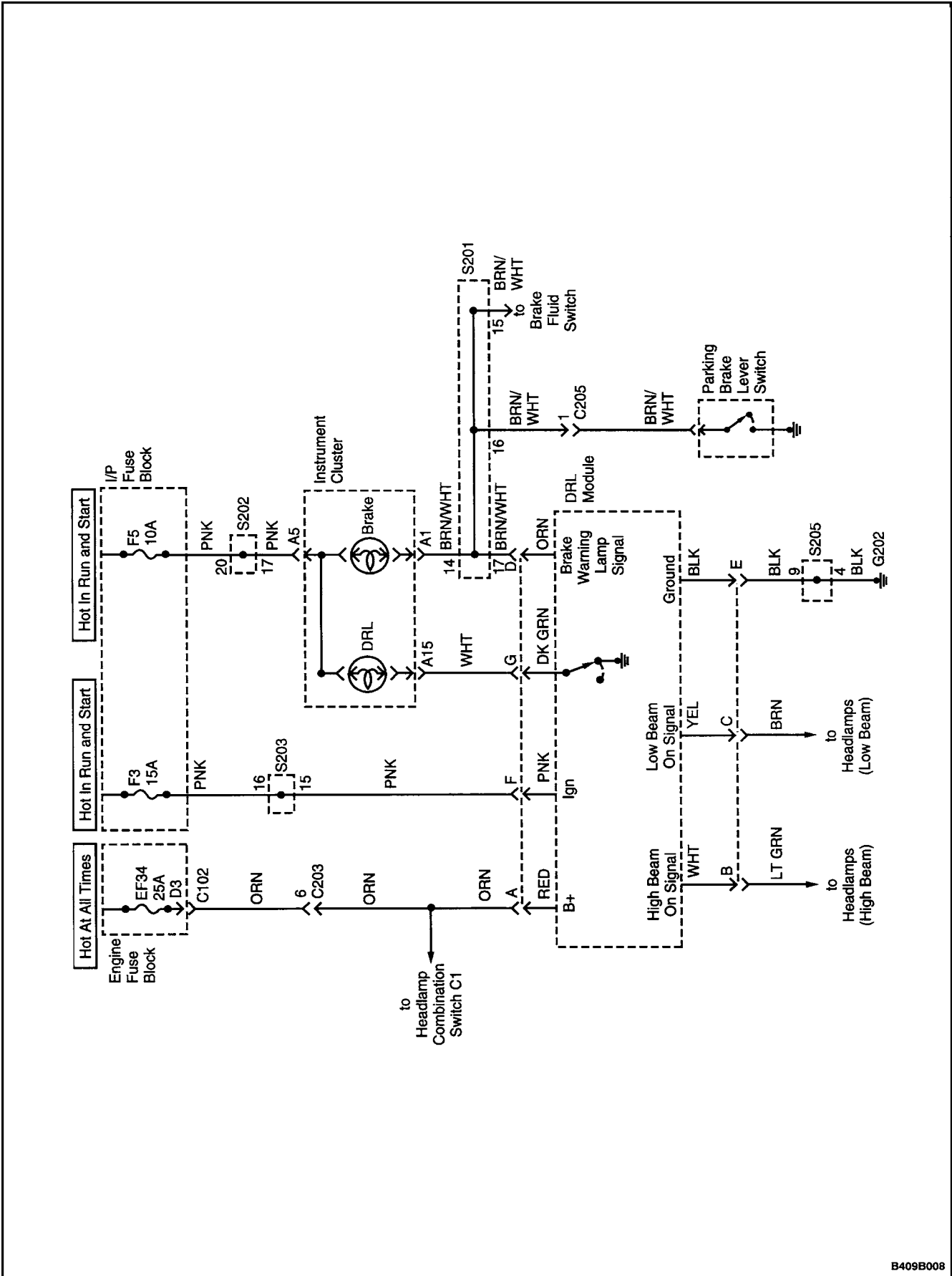

FOG LAMPS CIRCUIT

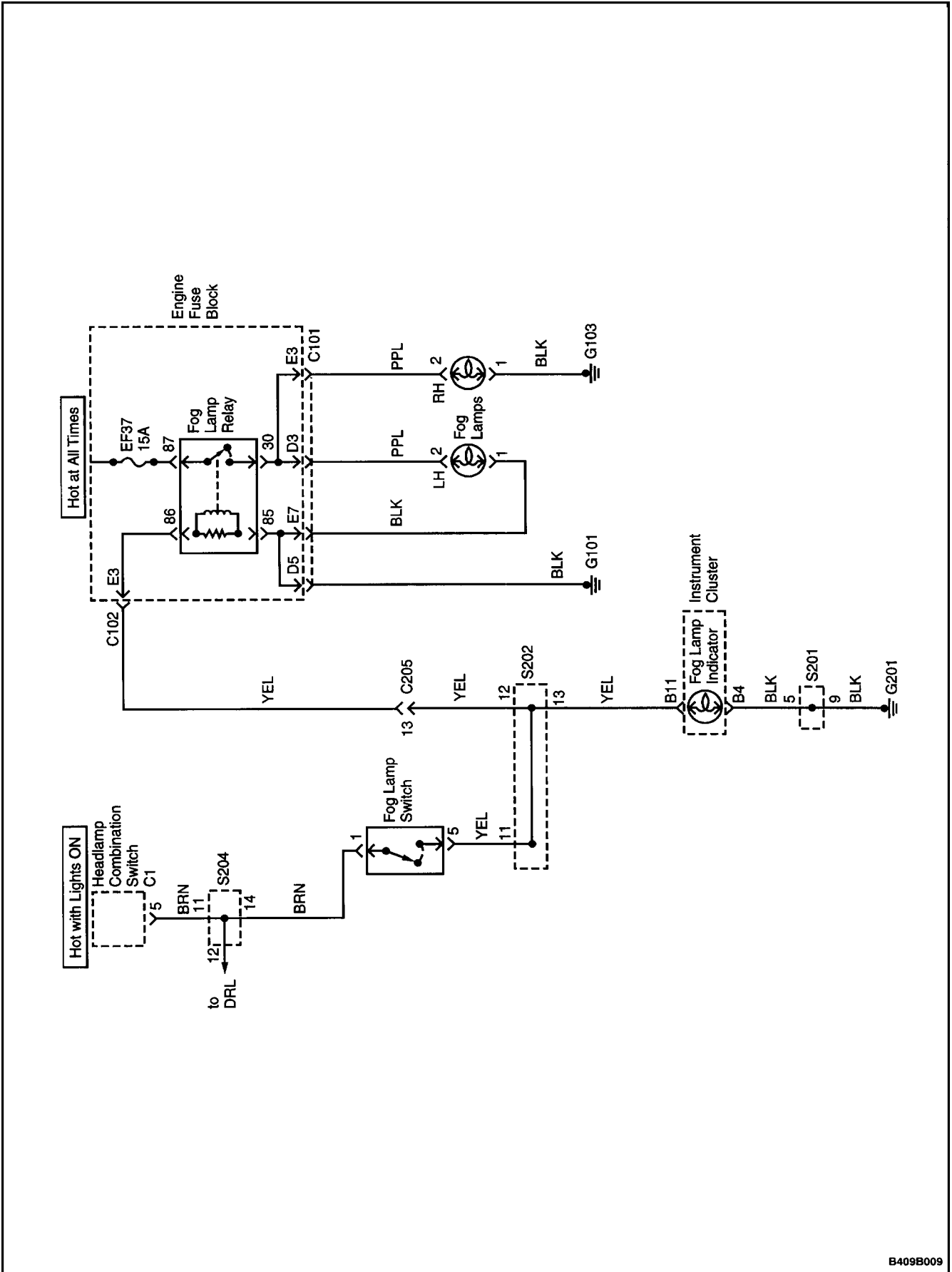

DIAGNOSIS

HEADLAMPS–ON REMINDER CHIME

Headlamp Reminder Chime Is Inoperative

Step	Action	Value(s)	Yes	No
1	Check the parking lamps. Do the parking lamps work?		Go to <i>Step 3</i>	Go to <i>Step 2</i>
2	Repair the parking lamps. Is the repair complete?		Go to <i>Step 3</i>	Go to <i>Step 2</i>
3	Check fuse EF20. Is fuse EF20 blown?		Go to <i>Step 4</i>	Go to <i>Step 5</i>
4	1. Check for a short circuit and repair it, if necessary. 2. Replace fuse EF20. Is the repair complete?		System OK	
5	1. Turn the parking lamps on. 2. Use a voltmeter to check the voltage at fuse EF20. Is the specified voltage available at fuse EF20?	11–14 v	Go to <i>Step 7</i>	Go to <i>Step 6</i>
6	Repair the open powersupply circuit for fuse EF20. Is the repair complete?		System OK	
7	1. Disconnect the chime module. 2. Turn the parking lamps on. 3. Check the voltage at terminal 6 of the chime module connector. Is the voltage equal to the specified value?	11–14 v	Go to <i>Step 9</i>	Go to <i>Step 8</i>
8	Repair the open circuit between fuse EF20 and terminal 6 of the chime module. Is the repair complete?		System OK	
9	With the chime module disconnected, use an ohmmeter to check the resistance between ground and terminal 5 of the chime module connector. Is the resistance equal to the specified value?	$\approx 0 \Omega$	Go to <i>Step 11</i>	Go to <i>Step 10</i>
10	Repair the open circuit between ground and terminal 5 of the chime module. Is the repair complete?		System OK	
11	1. Open the driver door. 2. With the chime module disconnected, use an ohmmeter to check the resistance between ground and terminal 4 of the chime module connector. Is the resistance equal to the specified value?	$\approx 0 \Omega$	Go to <i>Step 15</i>	Go to <i>Step 12</i>
12	1. Remove the driver door–open switch. 2. Use an ohmmeter to check the resistance between terminal 4 of the chime module connector and terminal 1 of the driver door–open switch. Does the ohmmeter show the specified value?	$\approx 0 \Omega$	Go to <i>Step 14</i>	Go to <i>Step 13</i>

9B – 12 LIGHTING SYSTEMS

Step	Action	Value(s)	Yes	No
13	Repair the open wire between the driver door–open switch and terminal 4 of the chime module connector. Is the repair complete?		System OK	
14	Replace the driver door–open switch. Is the repair complete?		System OK	
15	Replace the chime module. Is the repair complete?		System OK	

HEADLAMPS

Low–Beam Headlamps Are Inoperative, High–Beam Headlamps Are OK

Step	Action	Value(s)	Yes	No
1	Check fuses EF31 (left side headlamps) and EF26 (right side headlamps). Is fuse EF31 or EF26 blown?		Go to <i>Step 2</i>	Go to <i>Step 3</i>
2	1. Check for a short circuit and repair if necessary. 2. Replace the fuse. Is the repair complete?		System OK	
3	Check the voltage at fuses EF31 and EF26. Are the voltages equal to the specified value?	11–14 v	Go to <i>Step 4</i>	Go to <i>Step 9</i>
4	1. Disconnect both headlamp connectors. 2. Turn the headlamps ON. 3. Select the low beams. Is the voltage at each headlamp connector terminal 5 equal to the specified value?	11–14 v	Go to <i>Step 6</i>	Go to <i>Step 5</i>
5	Repair the open circuit between fuses EF31 or EF26 and the low beam headlamps. Is the repair complete?		System OK	
6	1. Disconnect the headlamp connectors. 2. Connect an ohmmeter between ground and either headlamp connector terminal 6. Is the resistance equal to the value specified?	0 Ω	Go to <i>Step 8</i>	Go to <i>Step 7</i>
7	Repair the ground circuit. Is the repair complete?		System OK	
8	Replace the faulty headlamps. Is the repair complete?		System OK	
9	1. Disconnect the headlamp combination switch connector C1. 2. Select the low beams. 3. Use an ohmmeter to check the continuity between terminals 6 and 5 of the headlamp combination switch. Does the ohmmeter indicate the value specified?	0 Ω	Go to <i>Step 10</i>	Go to <i>Step 11</i>

Step	Action	Value(s)	Yes	No
10	Replace the headlamp combination switch. Is the repair complete?		System OK	
11	Repair the open circuit between fuses EF31 and EF26 and the headlamp combination switch connector C1 (terminal 5). Is the repair complete?		System OK	

High-Beam Headlamps Are Inoperative, Low-Beam Headlamps Are OK

Step	Action	Value(s)	Yes	No
1	Check the high-beam headlamps in the "flash-to-pass" mode. Do the high-beam headlamps work in the "flash-to-pass" mode?		Go to <i>Step 8</i>	Go to <i>Step 2</i>
2	Check fuses EF30 and EF25. Is either fuse blown?		Go to <i>Step 3</i>	Go to <i>Step 4</i>
3	1. Check for a short circuit. Repair it if necessary. 2. Replace the fuse. Is the repair complete?		System OK	
4	1. Turn the high-beam headlamps ON. 2. Check the voltage at fuses EF21 and EF22. Are the voltages equal to the specified value?	11–14 v	Go to <i>Step 5</i>	Go to <i>Step 10</i>
5	1. Turn the high-beam headlamps ON. 2. Check the voltage at headlamp terminal 4. Does the voltage available at the headlamp connector terminal 4 equal the value specified?	11–14 v	Go to <i>Step 7</i>	Go to <i>Step 6</i>
6	Repair the open circuit between fuse EF30 or EF25 and the high-beam headlamps. Is the repair complete?		System OK	
7	Replace the faulty headlamps. Is the repair complete?		System OK	
8	1. Disconnect the headlamp combination switch connector. 2. Put the switch in the high-beam position. 3. Use an ohmmeter to check the continuity of the headlamp switch between terminals 7 and 4. Does the ohmmeter indicate the specified value?	0 Ω	Go to <i>Step 10</i>	Go to <i>Step 9</i>
9	Replace the headlamp combination switch. Is the repair complete?		System OK	
10	Repair the open circuit between headlamp combination switch connector C1 (terminal 4) and fuse EF30 or EF25. Is the repair complete?		System OK	

High-Beam and Low-Beam Headlamps Are Inoperative On Both Left and Right Sides

9B – 14 LIGHTING SYSTEMS

Step	Action	Value(s)	Yes	No
1	Check fuses EF34, EF30, EF25, EF31, EF26, and EF24. Is any fuse blown?		Go to <i>Step 2</i>	Go to <i>Step 3</i>
2	1. Check for a short circuit and repair if necessary. 2. Replace the fuse. Is the repair complete?		System OK	
3	1. Turn the low-beam headlamps ON. 2. Check the voltage at fuses EF24 and EF25. 3. Check the voltage at fuses EF21 and EF22 with high beams selected. Is the voltage equal to the specified value?	11–14 v	Go to <i>Step 4</i>	Go to <i>Step 9</i>
4	1. Turn the low-beam headlamps ON. 2. Check the voltage at the headlamp connector terminal 5. 3. Turn the high-beam headlamps ON. 4. Check the voltage at headlamp connector terminal 4. Does the battery voltage available at the headlamps equal the value specified?	11–14 v	Go to <i>Step 6</i>	Go to <i>Step 5</i>
5	Repair the open circuit between fuses EF30, EF25, EF31, and EF26 and the headlamps. Is the repair complete?		System OK	
6	Use an ohmmeter to check between ground and the headlamp connector terminal 6. Is the resistance equal to the specified value?	0 Ω	Go to <i>Step 8</i>	Go to <i>Step 7</i>
7	Repair the ground circuit. Is the repair complete?		System OK	
8	1. Replace the faulty headlamps. 2. Check the charging system to make sure that charging voltage is not excessively high. Repair if necessary. Is the repair complete?		System OK	
9	Use a voltmeter to check for power to fuses EF34 and EF29. Is the voltage equal to the specified value?	11–14 v	Go to <i>Step 11</i>	Go to <i>Step 10</i>
10	Repair the power supply circuit to fuses EF34 and EF29. Is the repair complete?		System OK	
11	Temporarily substitute the illumination relay in place of the headlamp relay. Do the headlamps operate with the substituted relay?		Go to <i>Step 12</i>	Go to <i>Step 13</i>
12	Install the illumination relay in its original position, and install a new headlamp relay. Is the repair complete?		System OK	
13	1. Return the illumination relay to its original position, but do not install the headlamp relay. 2. Use a voltmeter to check the headlamp relay connector for terminal 30. Does the voltmeter indicate the value specified?	11–14 v	Go to <i>Step 15</i>	Go to <i>Step 14</i>

Step	Action	Value(s)	Yes	No
14	Replace the engine fuse block. Is the repair complete?		System OK	
15	With the headlamp relay removed, use a voltmeter to check the headlamp relay connector terminal 85. Does the voltmeter indicate the value specified?	11–14 v	Go to <i>Step 16</i>	Go to <i>Step 14</i>
16	1. With the headlamp relay removed, turn the headlamps to low-beam. 2. Use an ohmmeter to check the continuity between connector relay terminal 86 and ground. Does the ohmmeter indicate the specified value?	$\approx 0 \Omega$	Go to <i>Step 22</i>	Go to <i>Step 17</i>
17	1. Reinstall the headlamp relay. 2. Check the voltage at the headlamp switch connector C2 (terminal 2). Does the voltage equal the specified value?	11–14 v	Go to <i>Step 19</i>	Go to <i>Step 18</i>
18	Repair the open circuit between headlamp relay terminal 85 and the headlamp switch connector C2 terminal 2. Is the repair complete?		System OK	
19	1. Disconnect the headlamp switch connector C2. 2. Turn the low-beam headlamps ON. 3. Use an ohmmeter to check the continuity between terminals 2 and 3 of headlamp combination switch C2. Does the ohmmeter indicate the specified value?	$\approx 0 \Omega$	Go to <i>Step 21</i>	Go to <i>Step 20</i>
20	Replace the headlamp switch. Is the repair complete?		System OK	
21	Repair the open circuit between terminal 3 of headlamp switch connector C2 and ground. Is the repair complete?		System OK	
22	Check the voltage at headlamp switch connector C1, (terminal 6). Does the voltage equal the specified value?	11–14 v	Go to <i>Step 24</i>	Go to <i>Step 23</i>
23	Repair the open circuit between headlamp switch connector C1 and terminal 87 of the headlamp relay. Is the repair complete?		System OK	
24	1. Disconnect headlamp switch connector C1. 2. Turn the headlamps to the low-beam position. 3. Connect an ohmmeter between terminals 5 and 6 of headlamp switch connector C1. 4. Turn the high-beam headlamps ON. 5. Connect an ohmmeter between terminals 4 and 6 of the headlamp switch. Does the ohmmeter show the specified value for both of the tests?	$\approx 0 \Omega$	Go to <i>Step 25</i>	Go to <i>Step 20</i>
25	Repair the open circuit between the headlamp switch and fuses EF30, EF25, EF31, and EF26. Is the repair complete?		System OK	

Diagnostic Aids

The daytime running lamp (DRL) system will not work if the parking brake is applied. The system is designed to work only when the engine is running and the parking brake is released. If the parking brake circuit is shorted to ground or the switch stays closed when the engine is running, the DRL system will not work.

Daytime Running Lamps Do Not Turn ON

Step	Action	Value(s)	Yes	No
1	Turn the headlamps ON. Do the headlamps work?		Go to <i>Step 3</i>	Go to <i>Step 2</i>
2	Repair the headlamp system. Is the repair complete?		System OK	Go to <i>Step 3</i>
3	Check fuse EF34. Is fuse EF34 blown?		Go to <i>Step 4</i>	Go to <i>Step 5</i>
4	1. Check for a short circuit and repair it, if necessary. 2. Replace fuse EF34. Is the repair complete?		System OK	
5	1. Turn the ignition ON. 2. Check the voltage at fuse EF34. Is the voltage equal to the specified value?	11–14 v	Go to <i>Step 7</i>	Go to <i>Step 6</i>
6	Repair the power supply circuit to fuse EF34. Is the repair complete?		System OK	
7	<ul style="list-style-type: none"> • Disconnect the electrical connector from the daytime running lamp (DRL) module. • Turn the ignition ON. • Check the voltage at terminal A of the DRL module. Is the voltage equal to the specified value?	11–14 v	Go to <i>Step 9</i>	Go to <i>Step 8</i>
8	Repair the open circuit between fuse EF34 and terminal A of the DRL module connector. Is the repair complete?		System OK	
9	With the DRL module still disconnected, use an ohmmeter to check the resistance between ground and terminal E of the DRL module connector. Is the resistance equal to the specified value?	$\approx 0 \Omega$	Go to <i>Step 11</i>	Go to <i>Step 10</i>
10	Repair the circuit between ground and terminal E of the DRL module connector. Is the repair complete?		System OK	
11	<ul style="list-style-type: none"> • Release the parking brake. • Turn the ignition ON. • Observe the parking brake indicator lamp. Is the parking brake indicator lamp ON?		Go to <i>Step 12</i>	Go to <i>Step 15</i>
12	Disconnect the electrical connector to the parking brake switch. Is the parking brake indicator lamp still ON?		Go to <i>Step 13</i>	Go to <i>Step 14</i>
13	Repair the short to ground in the parking brake circuit. Is the repair complete?		System OK	
14	Replace the parking brake switch. Is the repair complete?		System OK	
15	<ul style="list-style-type: none"> • Turn the headlamps OFF. • With the DRL module disconnected, turn the ignition ON. • Check the voltage at terminal F of the DRL module. Is the voltage equal to the specified value?	0 v	Go to <i>Step 17</i>	Go to <i>Step 16</i>

Step	Action	Value(s)	Yes	No
16	Repair the open circuit between fuse F3 and terminal F of the DRL module. Is the repair complete?		System OK	
17	Replace the DRL module. Is the repair complete?		System OK	

FOG LAMPS

Diagnostic Aids

The front fog lamp switch is powered by the headlamp switch, so the fog lamps may not operate if the headlamps or tail-lamps will not turn ON.

Fog Lamps Do Not Work on Either Side

Step	Action	Value(s)	Yes	No
1	Check the headlamps and the exterior lamps. Are the headlamps and the exterior lamps working?		Go to <i>Step 3</i>	Go to <i>Step 2</i>
2	Repair the headlamps and exterior lamp systems. Is the repair complete?		Go to <i>Step 3</i>	
3	Check fuse EF20. Is fuse EF20 blown?		Go to <i>Step 5</i>	Go to <i>Step 4</i>
4	1. Check for a short circuit and repair if necessary. 2. Replace fuse EF20. Is the repair complete?		System OK	
5	Use a voltmeter to check if battery voltage is available at fuse EF20. Is the voltage equal to the specified value?	11–14 v	Go to <i>Step 7</i>	Go to <i>Step 6</i>
6	Repair the power supply to fuse EF20. Is the repair complete?		System OK	
7	1. Disconnect the connectors at the front fog lamps. 2. Use an ohmmeter to check the resistance between ground and the BLK wire at the fog lamps. Does the ohmmeter indicate the specified value?	$\approx 0 \Omega$	Go to <i>Step 9</i>	Go to <i>Step 8</i>
8	Repair the open ground circuit for the front fog lamps. Is the repair complete?		System OK	
9	1. With the fog lamps disconnected, turn the front fog lamps to the ON position. 2. Turn the headlamps ON. 3. Check the voltage at the PPL wire at the front fog lamp connectors. Is the voltage equal to the specified value?	11–14 v	Go to <i>Step 10</i>	Go to <i>Step 11</i>
10	Replace the fog lamp bulbs. Is the repair complete?		System OK	
11	1. Temporarily substitute the exterior illumination relay (taillamp relay) in place of the front fog lamp relay. 2. Turn the headlamps ON. 3. Turn the fog lamps. Do the front fog lamps work with the substituted relay?		Go to <i>Step 12</i>	Go to <i>Step 13</i>
12	1. Return the substituted relay to its original position. 2. Replace the front fog lamp relay. Is the repair complete?		System OK	

Step	Action	Value(s)	Yes	No
13	<ol style="list-style-type: none"> Return the substituted relay to its original position, but do not reinstall the fog lamp relay. Use a voltmeter to probe each of the four terminals in the front fog lamp relay socket. <p>Does one of the four terminals in the relay socket indicate the specified value?</p>	11–14 v	Go to <i>Step 15</i>	Go to <i>Step 14</i>
14	<p>Replace the engine fuse block. Is the repair complete?</p>		System OK	
15	<ol style="list-style-type: none"> Turn the headlamps ON. Turn the fog lamps ON. Probe the front fog lamp relay socket with the voltmeter. <p>Besides the terminal which indicated battery voltage in Step 13, does another terminal in the relay socket (relay coil positive terminal) now indicate the specified value?</p>	11–14 v	Go to <i>Step 21</i>	Go to <i>Step 16</i>
16	<ol style="list-style-type: none"> Turn the headlamps ON. Check the voltage at the BRN wire at the front fog lamp switch. <p>Does the voltmeter indicate the specified value?</p>	11–14 v	Go to <i>Step 18</i>	Go to <i>Step 17</i>
17	<p>Repair the open circuit between the headlamp switch and the front fog lamp switch. Is the repair complete?</p>		System OK	
18	<ol style="list-style-type: none"> With the front fog lamp switch disconnected, connect an ohmmeter between the two terminals of the front fog lamp switch. Turn the front fog lamp switch to the ON position. <p>Does the ohmmeter indicate the specified value?</p>	0 Ω	Go to <i>Step 20</i>	Go to <i>Step 19</i>
19	<p>Replace the front fog lamp switch. Is the repair complete?</p>		System OK	
20	<p>Repair the open circuit between the front fog lamp switch and the front fog lamp relay. Is the repair complete?</p>		System OK	
21	<p>Check the resistance between ground and the ground terminal at the fog lamp relay socket. Does the ohmmeter indicate the specified value?</p>	$\approx 0 \Omega$	Go to <i>Step 23</i>	Go to <i>Step 22</i>
22	<p>Repair the ground circuit for the front fog lamp relay. Is the repair complete?</p>		System OK	
23	<p>Repair the open circuit between the front fog lamp relay and the front fog lamps. Is the repair complete?</p>		System OK	

REAR COMBINATION LAMPS

Exterior Illumination Lamps Do Not Work

9B – 20 LIGHTING SYSTEMS

Step	Action	Value(s)	Yes	No
1	Check the headlamps. Do the headlamps work?		Go to <i>Step 3</i>	Go to <i>Step 2</i>
2	Repair the headlamps. After the headlamps have been repaired, are the rear combination lamps still inoperative?		Go to <i>Step 3</i>	System OK
3	1. Turn the illumination lamps ON. 2. Use a voltmeter to check voltage at the bulb socket positive terminal. Is the voltage equal to the specified value?	11–14 v	Go to <i>Step 4</i>	Go to <i>Step 7</i>
4	Connect an ohmmeter between ground and the lamp socket negative terminal. Is the resistance equal to the specified value?	0 Ω	Go to <i>Step 6</i>	Go to <i>Step 5</i>
5	Repair the ground circuit for the lamps. Is the repair complete?		System OK	
6	Replace the faulty bulbs. Is the repair complete?		System OK	
7	Check fuses EF20 and EF21. Is either of the fuses blown?		Go to <i>Step 8</i>	Go to <i>Step 9</i>
8	1. Check for a short circuit and repair if necessary. 2. Replace the fuse. Is the repair complete?		System OK	
9	1. Temporarily substitute the headlamp relay in place of the illumination relay. 2. Turn the illumination lamps ON. Do the taillamps illuminate?		Go to <i>Step 10</i>	Go to <i>Step 11</i>
10	1. Return the headlamp relay to its original position. 2. Replace the illumination relay. Is the repair complete?		System OK	
11	1. Remove the illumination relay. 2. Use a voltmeter to check the illumination relay socket at connector terminal 87. Is the voltage equal to the specified value?	11–14 v	Go to <i>Step 13</i>	Go to <i>Step 12</i>
12	Replace the engine fuse block. Is the repair complete?		System OK	
13	With the illumination relay removed, use a voltmeter to check the illumination relay socket at connector terminal 86. Is the voltage equal to the specified value?	11–14 v	Go to <i>Step 14</i>	Go to <i>Step 12</i>
14	With the illumination relay removed, connect an ohmmeter between ground and connector terminal 85. the resistance equal to the specified value?	$\approx 0 \Omega$	Go to <i>Step 15</i>	Go to <i>Step 17</i>
15	1. Reinstall the illumination relay. 2. Turn the illumination lamps ON. 3. Check the voltage at EF20 and EF21. Is the voltage equal to the specified value?	11–14 v	Go to <i>Step 16</i>	Go to <i>Step 12</i>

Step	Action	Value(s)	Yes	No
16	Repair the open circuit between the fuses EF 21 and EF20 and the illumination lamps. Is the repair complete?		System OK	
17	1. Disconnect the headlamp switch connector C2. 2. Connect a fused jumper wire between ground and terminal 6 of connector C2 (instrument harness side). Do the illumination lamps turn ON with the jumper in place?		Go to <i>Step 19</i>	Go to <i>Step 18</i>
18	Repair the open circuit between terminal 85 of the illumination relay and terminal 6 of headlamp switch connector C2. Is the repair complete?		System OK	
19	1. Disconnect headlamp switch connector C2. 2. On the disconnected switch, select the illumination lamp ON position. 3. At the switch side of the connector C2, use an ohmmeter to check resistance between terminal 3 and terminal 6. Is the resistance equal to the specified value?	$\approx 0 \Omega$	Go to <i>Step 20</i>	Go to <i>Step 21</i>
20	Repair the open circuit between headlamp switch connector C2 terminal 3 and ground. Is the repair complete?		System OK	
21	Replace the headlamp switch. Is the repair complete?		System OK	

Stoplamps Do Not Work

Step	Action	Value(s)	Yes	No
1	Check fuse EF24. Is fuse EF24 blown?		Go to <i>Step 2</i>	Go to <i>Step 3</i>
2	1. Check for a short circuit and repair if necessary. 2. Replace the fuse. Is the repair complete?		System OK	
3	1. Depress the brake pedal. 2. With the brake pedal depressed, check the positive terminals of the bulb sockets with a test lamp. Does the test lamp illuminate?		Go to <i>Step 4</i>	Go to <i>Step 6</i>
4	Connect an ohmmeter between ground and the stoplamp ground terminal. Is the resistance equal to the specified value?	0 Ω	Go to <i>Step 6</i>	Go to <i>Step 5</i>
5	Repair the ground circuit. Is the repair complete?		System OK	
6	1. Disconnect the wiring connector from the brakelamp switch. 2. Press the brake pedal. 3. Use an ohmmeter to check the continuity between terminals 2 and 1 of the stoplamp switch. Is the resistance equal to the specified value?	0 Ω	Go to <i>Step 8</i>	Go to <i>Step 7</i>
7	Replace the brakelamp switch. Is the repair complete?		System OK	
8	1. Disconnect the stoplamp switch electrical connector. 2. Check the voltage at terminal 2. Does the voltmeter show the specified value?	11–14 v	Go to <i>Step 10</i>	Go to <i>Step 9</i>
9	Repair the open circuit between the fuse EF24 and the stoplamp switch. Is the repair complete?		System OK	
10	Repair the open circuit between the stoplamp switch and the stoplamps. Is the repair complete?		System OK	

Center High–Mounted Stoplamp (CHMSL) Does Not Work

Step	Action	Value(s)	Yes	No
1	Check the stoplamps. Do the stoplamps work?		Go to <i>Step 3</i>	Go to <i>Step 2</i>
2	Repair the stoplamps. Does the center high–mounted stoplamp (CHMSL) work after the stoplamps have been repaired?		System OK	Go to <i>Step 3</i>
3	1. Remove the CHMSL bulb. 2. Visually and physically check the CHMSL bulb. Is the lamp bulb defective?		Go to <i>Step 4</i>	Go to <i>Step 5</i>
4	Replace the CHMSL bulb. Is the repair complete?		System OK	
5	1. Disconnect the CHMSL connector. 2. Use an ohmmeter to measure the resistance between ground and the BLK wire in the CHMSL connector. Is the resistance equal to the specified value?	0 Ω	Go to <i>Step 7</i>	Go to <i>Step 6</i>
6	Repair the open circuit between ground and the BLK wire in the CHMSL connector. Is the repair complete?		System OK	
7	Repair the open circuit between the stoplamp switch and the CHMSL. Is the repair complete?		System OK	

Backup Lamps Inoperative

Step	Action	Value(s)	Yes	No
1	<ol style="list-style-type: none"> 1. Block the wheels. 2. Apply the parking brake. 3. Turn the ignition ON. 4. Put the transaxle in REVERSE. 5. Remove one of the backup lamps from its socket. 6. Test the lamp socket positive terminal with a voltmeter. <p>Is the voltage equal to the specified value?</p>	11–14 v	Go to <i>Step 3</i>	Go to <i>Step 2</i>
2	<p>Repair the open circuit between fuse F7 and the backup lamps.</p> <p>Is the repair complete?</p>		System OK	
3	<p>Connect an ohmmeter between ground and the negative terminal at the bulb socket.</p> <p>Is the resistance equal to the specified value?</p>	0 Ω	Go to <i>Step 4</i>	Go to <i>Step 5</i>
4	<p>Replace the faulty backup lamps.</p> <p>Is the repair complete?</p>		System OK	
5	<ol style="list-style-type: none"> 1. Install the backup lamps. 2. Disconnect the electrical connector at the reverse switch. (On automatic transaxle vehicles, disconnect the neutral safety/backup switch). 3. Turn the ignition ON. 4. Put the transaxle in REVERSE. 5. Use a voltmeter to check the reverse switch terminal 1. (On automatic transaxle vehicles, test terminal B of the neutral safety/backup switch). <p>Is the voltage equal to the specified value?</p>	11–14 v	Go to <i>Step 7</i>	Go to <i>Step 6</i>
6	<p>Repair the open circuit between the backup lamps and the reverse switch (or the neutral safety/backup switch, if equipped with A/T).</p> <p>Is the repair complete?</p>		System OK	
7	<ol style="list-style-type: none"> 1. Put the transaxle in REVERSE. 2. Use an ohmmeter to check the continuity between reverse switch terminal 1 and terminal 2 terminals B and F on the neutral safety/backup switch in automatic transaxle vehicles). <p>Does the continuity between terminals 1 and 2 (terminals D and F with A/T) equal the specified value?</p>	0 Ω	Go to <i>Step 9</i>	Go to <i>Step 8</i>
8	<p>Replace the REVERSE switch (neutral safety/backup switch in automatic transaxle vehicles).</p> <p>Is the repair complete?</p>		System OK	
9	<p>Repair the ground circuit between the REVERSE switch (neutral safety/backup switch if equipped with A/T) and the backup lamps.</p> <p>Is the repair complete?</p>		System OK	

Turn Signal Lamps and Hazard Lamps Do Not Work

Step	Action	Value(s)	Yes	No
1	Check fuses F3 and EF12. Is either fuse blown?		Go to <i>Step 2</i>	Go to <i>Step 3</i>
2	1. Check for a short circuit and repair if necessary. 2. Replace the fuse. Is the repair complete?		System OK	
3	1. Turn the ignition ON. 2. Check the voltage at fuse EF12 and F3. Is the voltage equal to the specified value?	11–14 v	Go to <i>Step 4</i>	Go to <i>Step 7</i>
4	1. Turn the hazard switch ON. 2. Remove each of the inoperative lamps from its socket. 3. Test each lamp socket positive terminal with a voltmeter. Is the voltage equal to the specified value?	11–14 v	Go to <i>Step 5</i>	Go to <i>Step 9</i>
5	At each bulb socket, use an ohmmeter to check the ground circuit. Is the resistance equal to the specified value?	$\approx 0 \Omega$	Go to <i>Step 6</i>	Go to <i>Step 8</i>
6	Replace any faulty turn signal/hazard bulbs. Is the repair complete?		System OK	
7	Repair the power supply circuit to fuses. Is the repair complete?		System OK	
8	Repair the open ground wires. Is the repair complete?		System OK	
9	1. Turn the hazard lamps ON. 2. Test blinker unit connector terminal 49a with a voltmeter. Is the voltage equal to the specified value?	11–14 v	Go to <i>Step 15</i>	Go to <i>Step 10</i>
10	1. Turn the hazard lamps ON. 2. Test blinker unit connector terminal 49 with a voltmeter. Is the voltage equal to the specified value?	11–14 v	Go to <i>Step 11</i>	Go to <i>Step 14</i>
11	1. Disconnect the blinker unit from the connector. 2. Use an ohmmeter to check between ground and the connector for terminal 31 of the blinker connector. Is the resistance equal to the specified value?	$\approx 0 \Omega$	Go to <i>Step 13</i>	Go to <i>Step 12</i>
12	Repair the blinker unit ground circuit. Is the repair complete?		System OK	
13	Replace faulty blinker unit. Is the repair complete?		System OK	
14	1. Disconnect the hazard switch connector. 2. Check for voltage at terminal 8. 3. Turn the ignition ON. 4. Check for voltage at terminal 10. Does the voltage available at both terminals equal the specified value?	11–14 v	Go to <i>Step 16</i>	Go to <i>Step 15</i>

9B – 26 LIGHTING SYSTEMS

Step	Action	Value(s)	Yes	No
15	Repair the open circuit between the hazard switch and fuses F3 or EF12. Is the repair complete?		System OK	
16	With the hazard switch disconnected, use an ohmmeter to check for an open circuit between blinker unit terminal 49 and hazard switch connector terminal 7. Is there an open circuit?		Go to <i>Step 17</i>	Go to <i>Step 18</i>
17	Repair the open circuit between the hazard switch and the blinker unit. Is the repair complete?		System OK	
18	1. Remove the hazard switch. 2. Turn the hazard switch OFF. 3. Use an ohmmeter to check for continuity between terminals 7 and 10. 4. Turn the hazard switch ON. 5. Use an ohmmeter to check for continuity between terminals 7 and 8. Does the ohmmeter show the specified value for both tests?	0 Ω	Go to <i>Step 20</i>	Go to <i>Step 19</i>
19	Replace the hazard switch. Is the repair complete?		System OK	
20	1. With the hazard switch still removed for testing, turn the hazard switch to the ON position. 2. Use an ohmmeter to check the continuity between terminals 5, 6, and 9. Is there continuity between terminals 5, 6, and 9?		Go to <i>Step 19</i>	Go to <i>Step 21</i>
21	1. Disconnect connector C204. 2. Use an ohmmeter to check the continuity of the wire between the hazard switch terminal 5 and C204 terminal 1. Does the ohmmeter show the value specified?	∞	Go to <i>Step 23</i>	Go to <i>Step 22</i>
22	Repair the open wire between the hazard switch and C204. Is the repair complete?		System OK	
23	Use an ohmmeter to check the continuity of the wire between the hazard switch terminal 6 and C204 terminal 11. Does the ohmmeter show the specified value?	∞	Go to <i>Step 24</i>	Go to <i>Step 22</i>
24	Repair the open circuit between C204 and the turn signal bulbs. Is the repair complete?		System OK	

Hazard Lamps Do Not Operate, Turn Signals Are OK

Step	Action	Value(s)	Yes	No
1	Check fuse EF12. Is fuse EF12 blown?		Go to <i>Step 2</i>	Go to <i>Step 3</i>
2	1. Check for a short circuit and repair if necessary. 2. Replace the fuse. Is the repair complete?		System OK	
3	Use a voltmeter to check the voltage at fuse EF12. Is the voltage equal to the specified value?	11–14 v	Go to <i>Step 5</i>	Go to <i>Step 4</i>
4	Repair the power supply circuit to fuse EF12. Is the repair complete?		System OK	
5	1. Disconnect the hazard lamp switch connector. 2. Use a voltmeter to check the voltage at hazard switch terminal 8. Is the voltage equal to the specified value?	11–14 v	Go to <i>Step 6</i>	Go to <i>Step 9</i>
6	1. Remove the hazard lamp switch. 2. Turn the hazard lamps ON. 3. Use an ohmmeter to check the resistance between terminals 7 and 8. Is the resistance equal to the specified value?	0 Ω	Go to <i>Step 7</i>	Go to <i>Step 10</i>
7	1. With the hazard lamp switch still removed and disconnected for testing, turn the hazard lamp switch to the ON position. 2. Use an ohmmeter to check between terminals 5, 6, and 9. Is the resistance equal to the specified value?	0 Ω	Go to <i>Step 8</i>	Go to <i>Step 10</i>
8	Repair the open circuit between the hazard lamp switch connector and splice S204. Is the repair complete?		System OK	
9	Repair the open circuit between the hazard lamp switch connector terminal H and fuse EF12. Is the repair complete?		System OK	
10	Replace the faulty hazard lamp switch. Is the repair complete?		System OK	

INTERIOR COURTESY AND LUGGAGE COMPARTMENT LAMPS

Interior Courtesy Lamp Inoperative

CAUTION : Always make sure there is an electrical load (lamp bulb, etc.) in any circuit between battery terminals. Do not make a short circuit between battery terminals with a jumper wire. Hazardous sparking would result.

Test Description

The number(s) below refer to step(s) on the diagnostic

table.

1. Bulb test. Clip one end of a jumper wire to the negative battery terminal. Clip the other end of the jumper wire to the end of the bulb. Take the free end of the bulb (the end without the jumper attached) and touch it to the positive battery terminal.

Step	Action	Value(s)	Yes	No
1	1. Remove the interior courtesy lamp bulb and inspect the filament. 2. If the filament is not broken, test the bulb using the vehicle's battery and a jumper wire. Does the bulb pass the visual and physical checks?		Go to Step 3	Go to Step 2
2	Replace the bulb. Is the repair complete?		System OK	
3	1. Reinstall the interior courtesy lamp bulb. 2. Check fuse EF29. Is fuse EF29 blown?		Go to Step 4	Go to Step 5
4	1. Check for a short circuit and repair if necessary. 2. Replace the fuse. Is the repair complete?		System OK	
5	Check fuse EF29. Is the voltage equal to the specified value?	11–14 v	Go to Step 7	Go to Step 6
6	Repair the open circuit between the battery and fuse EF29. Is the repair complete?		System OK	
7	1. Disconnect the interior courtesy lamp electrical connector. 2. Check the voltage at the ORN wire. Is the voltage equal to the specified value?	11–14 v	Go to Step 8	Go to Step 9
8	Repair the open circuit between fuse EF29 and the interior courtesy lamp. Is the repair complete?		System OK	
9	Use an ohmmeter to check the resistance between ground and the BLK wire of the interior courtesy lamp connector (harness side). Is the resistance equal to the specified value?	0 Ω	Go to Step 10	Go to Step 11
10	Replace the interior courtesy lamp switch assembly. Is the repair complete?		System OK	
11	Repair the ground circuit for the interior courtesy lamp. Is the repair complete?		System OK	

Luggage Compartment Lamp Inoperative

CAUTION : Always make sure there is an electrical load (lamp bulb, etc.) in any circuit between battery terminals. Do not make a short circuit between battery terminals with a jumper wire. Hazardous sparking will result.

Test Description

The number(s) below refer to step(s) on the diagnostic

table.

1. Bulb test. Clip one end of a jumper wire to the negative battery terminal. Clip the other end of the jumper wire onto one end of the bulb. Take the free end of the bulb (the end without the jumper attached) and touch it to the positive battery terminal.

Step	Action	Value(s)	Yes	No
1	1. Remove the luggage compartment lamp bulb and inspect the filament. 2. If the filament is not broken, test the bulb using the vehicle's battery and a jumper wire. Does the bulb pass the visual and physical check?		Go to Step 3	Go to Step 2
2	Replace the bulb. Is the repair complete?		System OK	
3	1. Reinstall the luggage compartment lamp bulb. 2. Check fuse EF29. Is fuse EF29 blown?		Go to Step 4	Go to Step 5
4	1. Check for a short circuit and repair it, if necessary. 2. Replace the fuse. Is the repair complete?		System OK	
5	Check fuse EF29. Is the voltage equal to the specified value?	11–14 v	Go to Step 7	Go to Step 6
6	Repair the open circuit between the battery and fuse EF29. Is the repair complete?		System OK	
7	1. Disconnect the luggage compartment lamp electrical connector. 2. Check the voltage at the ORN wire. Does the voltage at the ORN wire equal the specified value?	11–14 v	Go to Step 8	Go to Step 9
8	Repair the open circuit between fuse EF29 and the luggage compartment lamp. Is the repair complete?		System OK	
9	1. Reconnect the luggage compartment lamp. 2. Remove the luggage compartment lamp (tailgate) switch. 3. With a voltmeter, test the PNK/BLK wire at the luggage compartment lamp (tailgate) switch. Is the voltage equal to the specified value?	11–14 v	Go to Step 11	Go to Step 10
10	Repair the open circuit between the luggage compartment lamp and the luggage compartment lamp (tailgate) switch. Is the repair complete?		System OK	
11	Use an ohmmeter to check the resistance between ground and the BLK wire at the luggage compartment (tailgate) lamp switch connector (harness side). Is the resistance equal to the specified value?	0 Ω	Go to Step 12	Go to Step 13

9B – 30 LIGHTING SYSTEMS

Step	Action	Value(s)	Yes	No
12	Replace the luggage compartment lamp (tailgate) switch. Is the repair complete?		System OK	
13	Repair the ground circuit for the interior courtesy lamp. Is the voltage equal to the specified value?		System OK	